

SERVICE MANUAL

QUEEN SERIES QUEEN MULTI SERIES

**ASH-09AQ, ASH-13AQ
ASH-09+12AQ**



2 Specifications and technical parameters

Model		ASH-09AQ	
Function		COOLING	HEATING
Rated Voltage		230 V~	
Rated Frequency		50Hz	
Total Capacity (W)		2500	2700
Power Input (W)		780	800
Rated Input (W)		900	1000
Rated Current (A)		3.91	4.35
Air Flow Volume (m ³ /h)		480	
Dehumidifying Volume (l/h)		1.3	
C.O.P / EER (W/W)		3.21	3.38
Indoor unit	Model of Indoor Unit	ASH-09AQ	
	Fan Motor Speed (r/min) (H/M/L)	1130/1010/920	
	Output of Fan Motor (w)	8	
	Input of Heater (w)	\	
	Fan Motor Capacitor (uF)	1	
	Fan Motor RLA(A)	0.11	
	Fan Type-Piece	Cross flow fan – 1	
	Diameter-Length (mm)	φ 92 X 616	
	Evaporator	Aluminum fin-copper tube	
	Pipe Diameter (mm)	φ 7	
	Row-Fin Gap(mm)	2-1.4	
	Coil length (l) x height (H) x coil width (L)	616x324x25.4	
	Swing Motor Model	MP24GA/ MP24CA	
	Output of Swing Motor(W)	2	
	Fuse (A)	PCB 3.15A Transformer 0.2A	
	Sound Pressure Level dB (A) (H/M/L)	38/36/34	
	Sound Power Level dB (A) (H/M/L)***	49/46.5/44	
	Dimension (W/D/H)(mm)	830x285x206	
	Dimension of Package (W/D/H)(mm)	905x390x280	
	Net Weight/Gross Weight (kg)	12/15	
Remote control		Y512	

Outdoor unit	Model of Outdoor Unit		ASH-09AQ
	Compressor Model		C-1RV096H1A
	Compressor Type		Scroll compressor
	L.R.A. (A)		17
	Compressor RLA(A)		3.8
	Compressor Power Input(W)		800
	Overload Protector		B150-145-241E
	Throttling Method		Capillary
	Starting Method		Capacitor
	Working Temp Range (°C)		-5°C ≤ T ≤ 43°C
	Condenser		Aluminum fin-copper tube
	Pipe Diameter (mm)		Φ9.52
	Rows-Fin Gap(mm)		2-1.4
	Coil length (l) x height (H) x coil width (L)		781.x508x44
	Fan Motor Speed (rpm) (H/ML)**		850
	Output of Fan Motor (W)		30
	Fan Motor RLA(A)		0.55
	Fan Motor Capacitor (uF)		3
	Air Flow Volume of Outdoor Unit		/
	Fan Type-Piece		Axial fan -1
	Fan Diameter (mm)		Φ400
	Defrosting Method		Auto defrost
	Climate Type		T1
	Isolation		I
	Moisture Protection		IP24
	Permissible Excessive Operating Pressure for the Discharge Side(MPa)		3.8
	Permissible Excessive Operating Pressure for the Suction Side(MPa)		1.2
	Sound Pressure Level dB (A) (H/ML)		54
	Sound Power Level dB (A) (H/ML)		64
	Dimension (W/D/H)(mm)		848X320 X540
Dimension of Package (W/D/H)(mm)		878X360 X600	
Net Weight /Gross Weight (kg)		30/35	
Refrigerant Charge (kg)		R410A/1.16	
Connecti on Pipe	Length (m)		4 m
	Outer Diameter	Liquid Pipe (mm)	Φ6(1/4")
		Gas Pipe (mm)	Φ9.52(3/8")
	Max Distance	Height (m)	10
Length (m)		15	

The technical data are subject to change without notice. Please refer to the nameplate of the unit.

Notice: If you wish longer length of pipe then 4 m, you have to fill the additional refrigerant.

Model		ASH-13AQ	
Function		COOLING	HEATING
Rated Voltage		230 V~	
Rated Frequency		50Hz	
Total Capacity (W)		3500	3700
Power Input (W)		1080	1050
Rated Input (W)		1250	1350
Rated Current (A)		5.4	5.9
Air Flow Volume (m ³ /h)		600	
Dehumidifying Volume (l/h)		1.3	
C.O.P / EER (W/W)		3.2	3.5
Indoor unit	Model of Indoor Unit	ASH-13AQ	
	Fan Motor Speed (r/min) (H/M/L)	1350/1200/1100	
	Output of Fan Motor (w)	22	
	Input of Heater (w)	\	
	Fan Motor Capacitor (uF)	1	
	Fan Motor RLA(A)	0.2	
	Fan Type-Piece	Cross flow fan – 1	
	Diameter-Length (mm)	φ92 X 616	
	Evaporator	Aluminum fin-copper tube	
	Pipe Diameter (mm)	φ7	
	Row-Fin Gap(mm)	2-1.4	
	Coil length (l) x height (H) x coil width (L)	616x324x25.4	
	Swing Motor Model	MP24GA/ MP24CA	
	Output of Swing Motor(W)	2	
	Fuse (A)	PCB 3.15A Transformer 0.2A	
	Sound Pressure Level dB (A) (H/M/L)	44/40/37	
	Sound Power Level dB (A) (H/M/L)***	55/53/50	
	Dimension (W/D/H)(mm)	830X285 X206 ASH	
	Dimension of Package (W/D/H)(mm)	905X390X280	
	Net Weight/Gross Weight (kg)	12/15	
Remote control		Y512	

Outdoor unit	Model of Outdoor Unit		ASH-13AQ
	Compressor Model		C-RV133H1A
	Compressor Type		Scroll compressor
	L.R.A. (A)		24
	Compressor RLA(A)		5.25
	Compressor Power Input(W)		1120
	Overload Protector		B210-145-241E
	Throttling Method		Capillary
	Starting Method		Capacitor
	Working Temp Range (°C)		-5°C ≤ T ≤ 43°C
	Condenser		Aluminum fin-copper tube
	Pipe Diameter (mm)		Φ9.52
	Rows-Fin Gap(mm)		2-1.4
	Coil length (l) x height (H) x coil width (L)		781.x508x44
	Fan Motor Speed (rpm) (H/ML)**		850
	Output of Fan Motor (W)		48
	Fan Motor RLA(A)		0.55
	Fan Motor Capacitor (uF)		3
	Air Flow Volume of Outdoor Unit		/
	Fan Type-Piece		Axial fan -1
	Fan Diameter (mm)		Φ400
	Defrosting Method		Auto defrost
	Climate Type		T1
	Isolation		I
	Moisture Protection		IP24
	Permissible Excessive Operating Pressure for the Discharge Side(MPa)		3.8
	Permissible Excessive Operating Pressure for the Suction Side(MPa)		1.2
	Sound Pressure Level dB (A) (H/ML)		56
	Sound Power Level dB (A) (H/ML)		66
	Dimension (W/D/H)(mm)		848X320 X540
Dimension of Package (W/D/H)(mm)		878X360 X600	
Net Weight /Gross Weight (kg)		40/45	
Refrigerant Charge (kg)		R410A/1.35	
Connecti on Pipe	Length (m)		4
	Outer Diameter	Liquid Pipe (mm)	Φ6(1/4")
		Gas Pipe (mm)	Φ12(1/2")
	Max Distance	Height (m)	10
Length (m)		15	

The technical data are subject to change without notice. Please refer to the nameplate of the unit.

Model		ASH-09+12AQ	
Function		COOLING	HEATING
Rated Voltage		230 V~	
Rated Frequency		50Hz	
Total Capacity (W)		2500+3500	2700+3700
Power Input (W)		860+1200	860+1200
Rated Input (W)		940+1425	920+1425
Rated Current (A)		4.08+6.19	4.4+6.19
Air Flow Volume (m ³ /h)		580	
Dehumidifying Volume (l/h)		1.2+1.3	
C.O.P / EER (W/W)		2.91	3.10
Indoor unit	Model of Indoor Unit	ASH-09AQ	ASH-12AQ
	Fan Motor Speed (r/min) (H/ML)	1130/1010/920	1350/1200/1100
	Output of Fan Motor (w)	8	22
	Input of Heater (w)	\	
	Fan Motor Capacitor (uF)	1	
	Fan Motor RLA(A)	0.11 (ASH-09AQ)	0.2 (ASH-13AQ)
	Fan Type-Piece	Cross flow fan – 1	
	Diameter-Length (mm)	φ92 X 616	
	Evaporator	Aluminum fin-copper tube	
	Pipe Diameter (mm)	φ7	
	Row-Fin Gap(mm)	2-1.4	
	Coil length (l) x height (H) x coil width (L)	616X324X25.4	
	Swing Motor Model	MP24GA/MP24CA	
	Output of Swing Motor(W)	2	
	Fuse (A)	PCB 3.15A Transformer 0.2A	
	Sound Pressure Level dB (A) (H/ML)	38/33/30	44/40/37
	Sound Power Level dB (A) (H/ML)***	48/44/40	54/50/47
	Dimension (W/D/H)(mm)	830X285X206	
	Dimension of Package (W/D/H)(mm)	905X390X280	
	Net Weight/Gross Weight (kg)	12/15	
Remote control		Y512	

Outdoor unit	Model of Outdoor Unit		ASH-09+12AQ	
	Compressor Model		5PS108 EAA22	C-RV146 H1A
	Compressor Type		Hermetic motor compressor	
	L.R.A (A)		28	24
	Compressor RLA(A)		18	5.6
	Compressor Power Input(W)		880	1000
	Overload Protector		KA-122-LPD021A	B210-145-241E
	Throttling Method		Capillary	
	Starting Method		Capacitor	
	Working Temp Range (°C)		-5°C ≤ T ≤ 43°C	
	Condenser		Aluminum fin-copper tube	
	Pipe Diameter (mm)		Φ9.52	
	Rows-Fin Gap(mm)		2-1.8	
	Coil length (l) x height (H) x coil width (L)		725X660X44	
	Fan Motor Speed (rpm) (H/ML)**		700	
	Output of Fan Motor (W)		38	
	Fan Motor RLA(A)		0.16	
	Fan Motor Capacitor (uF)		3	
	Air Flow Volume of Outdoor Unit		2300	
	Fan Type-Piece		Axial fan -1	
	Fan Diameter (mm)		Φ450	
	Defrosting Method		Auto defrost	
	Climate Type		T1	
	Isolation		I	
	Moisture Protection		IP24	
	Permissible Excessive Operating Pressure for the Discharge Side(MPa)		3.8	
	Permissible Excessive Operating Pressure for the Suction Side(MPa)		1.2	
	Sound Pressure Level dB (A)		58/55/52	
	Sound Power Level dB (A)		68/65/62	
	Dimension (W/D/H)(mm)		950X700X412	
	Dimension of Package (W/D/H)(mm)		1100X755X450	
Net Weight /Gross Weight (kg)		65/70		
Refrigerant Charge (kg)		R410A/0.90+1.25		
Connecti on Pipe	Length (m)		4	
	Outer Diameter	Liquid Pipe (mm)	Φ6(1/4")	
		Gas Pipe (mm)	Φ9.52 (3/8")	Φ16(5/8")
	Max Distance	Height (m)	10	
		Length (m)	20	

The technical data are subject to change without notice. Please refer to the nameplate of the unit.

3 Parts name

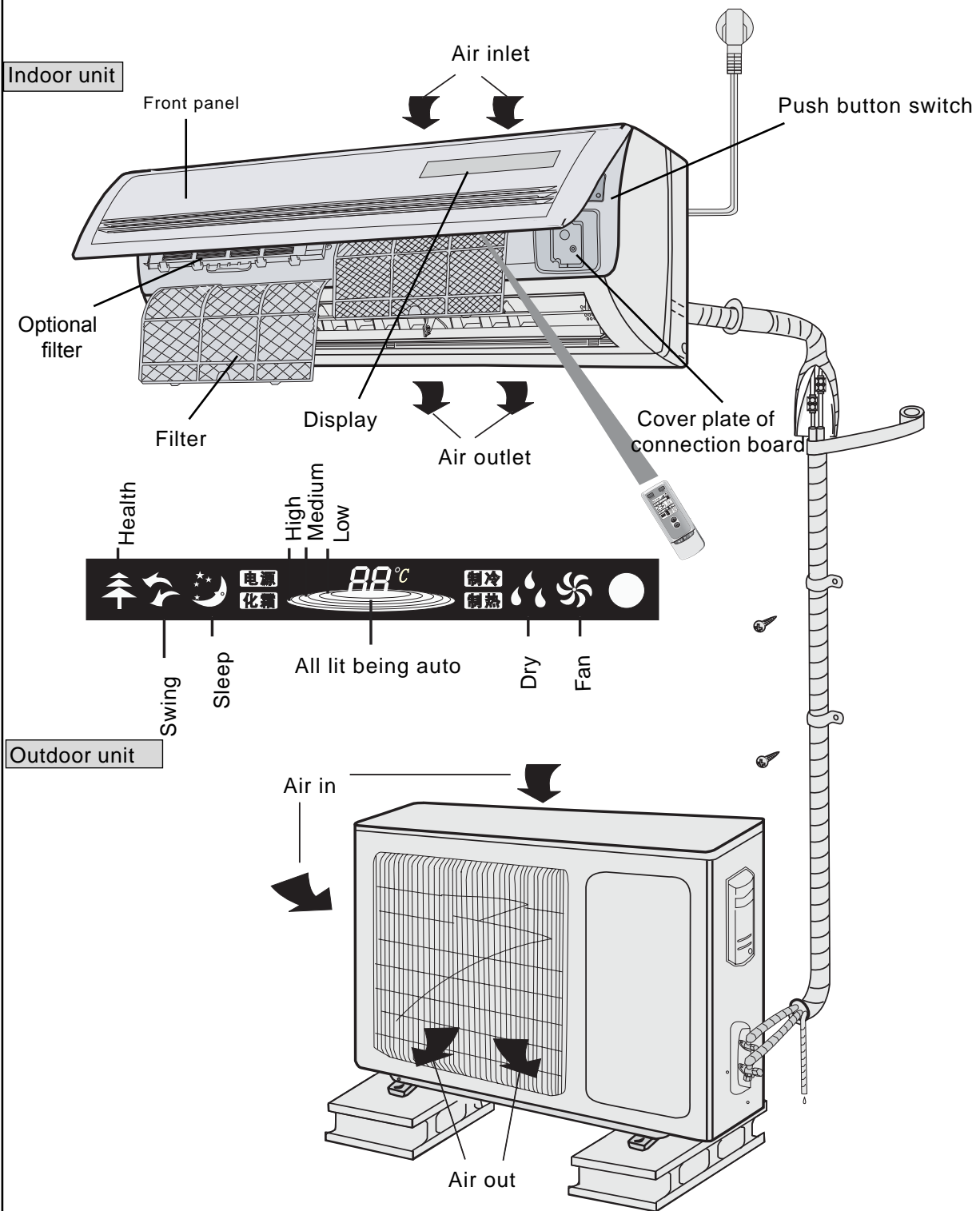

4 Outline and installation dimensions

4.1 Outline and installation dimensions of indoor unit

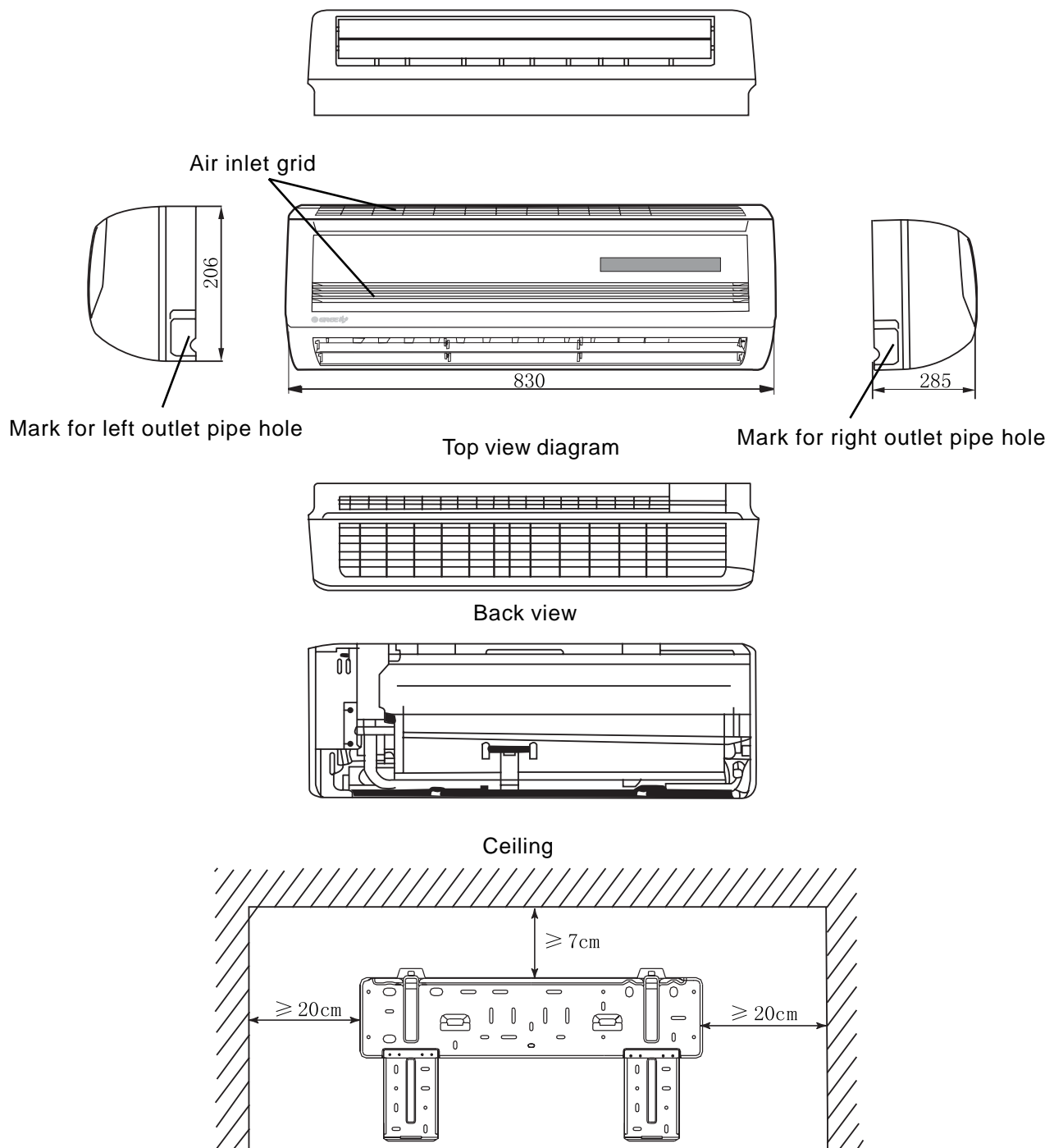

4.2 Outline and installation dimensions of outdoor unit

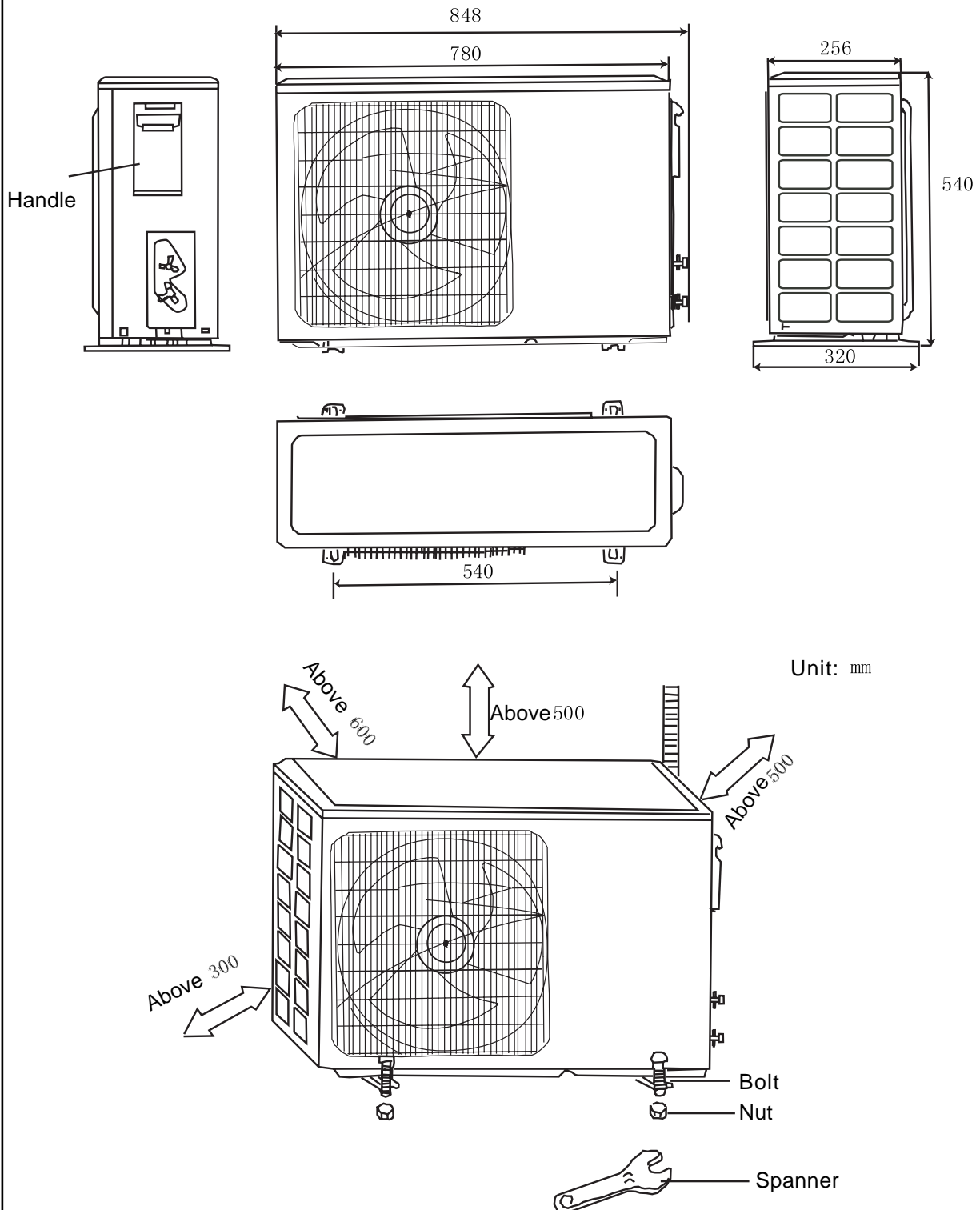

4. 4 Outline and installation dimensions of outdoor unit

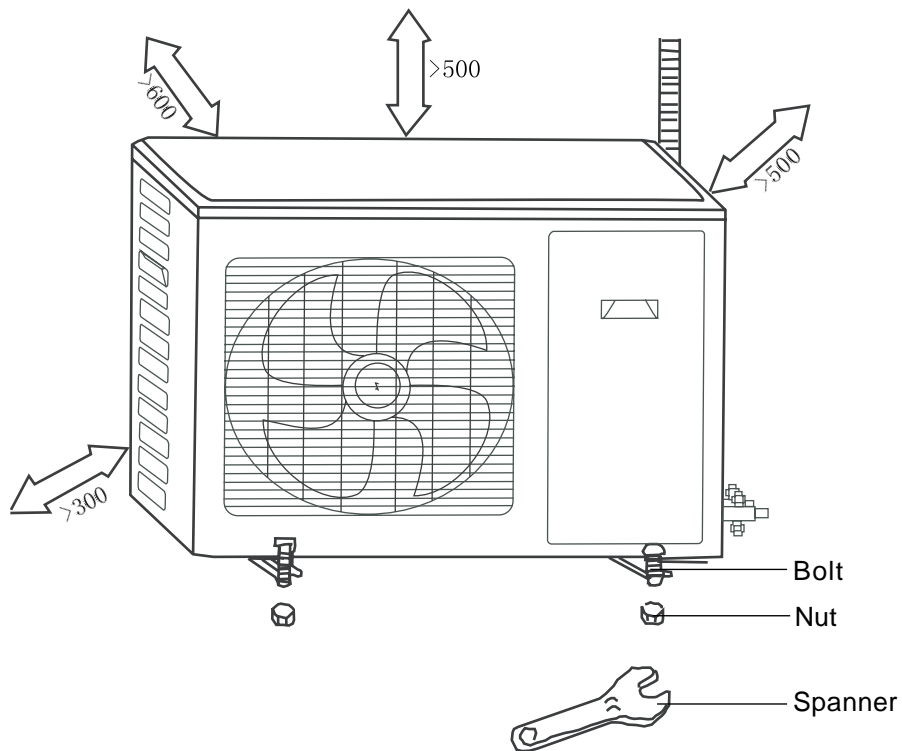
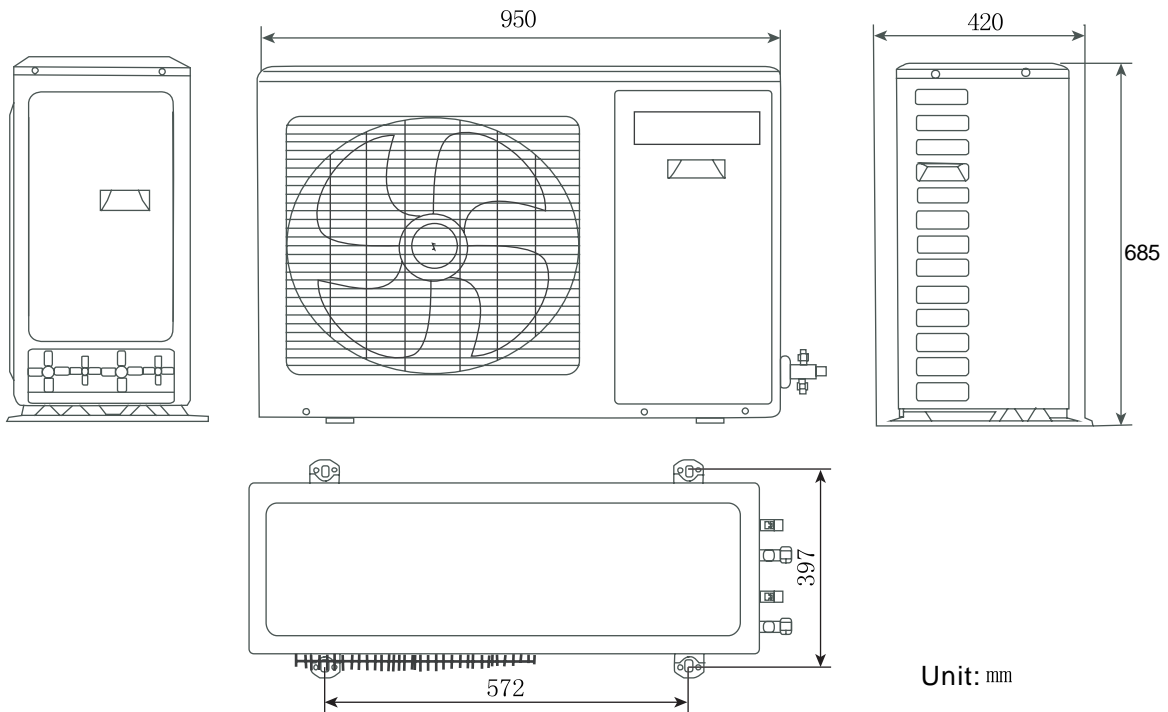

Model ASH-09+12AQ

5 Circuit diagram

ASH-09AQ

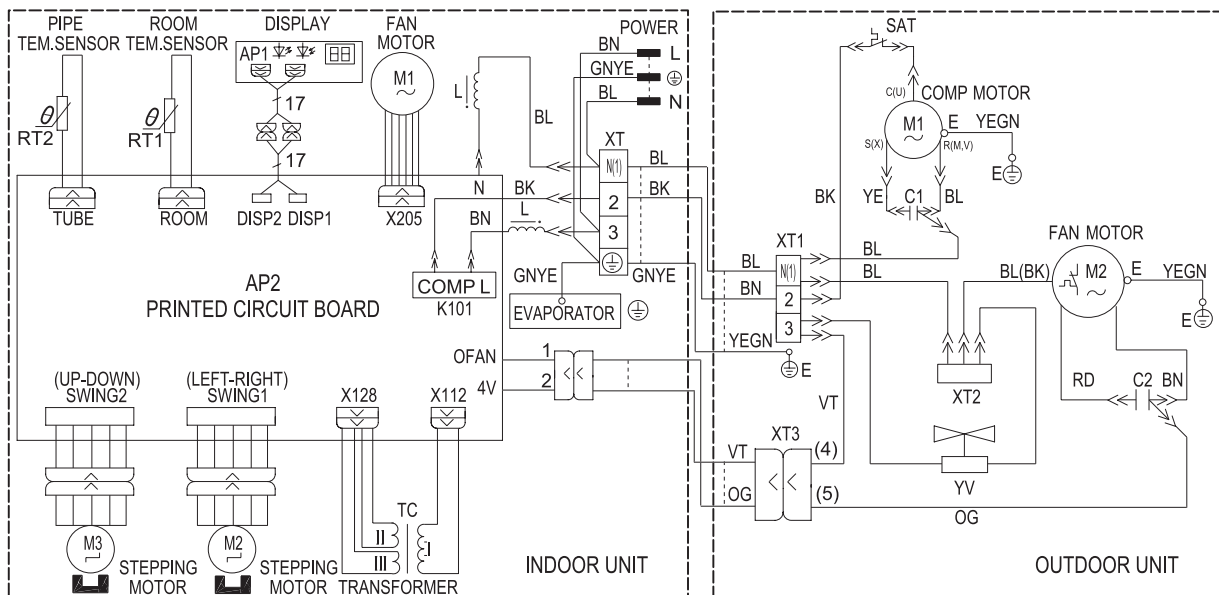

ASH-13AQ

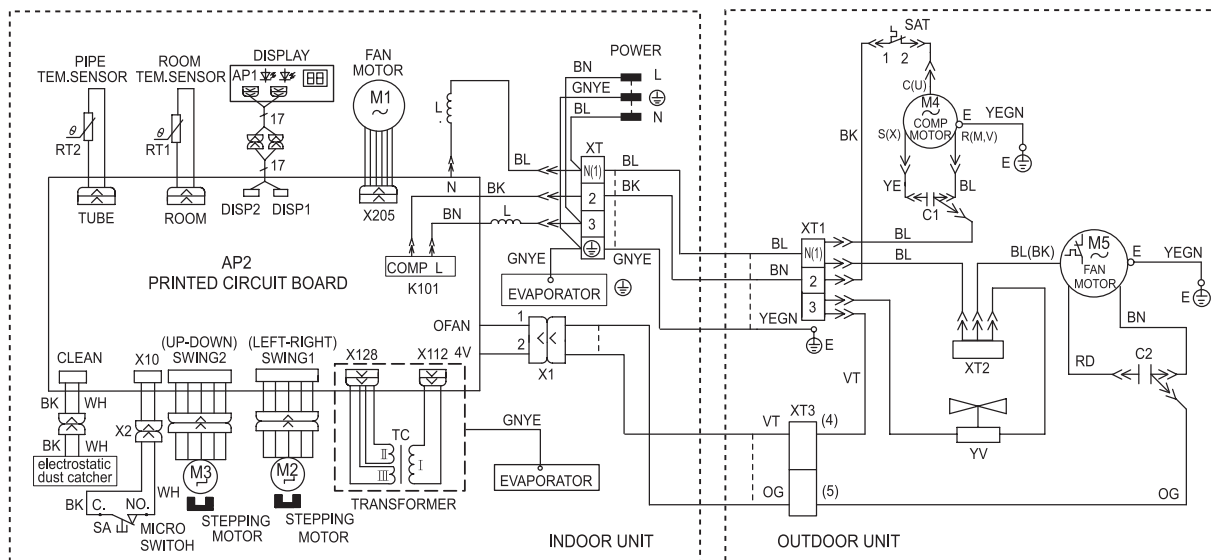

ASH-09+12AQ

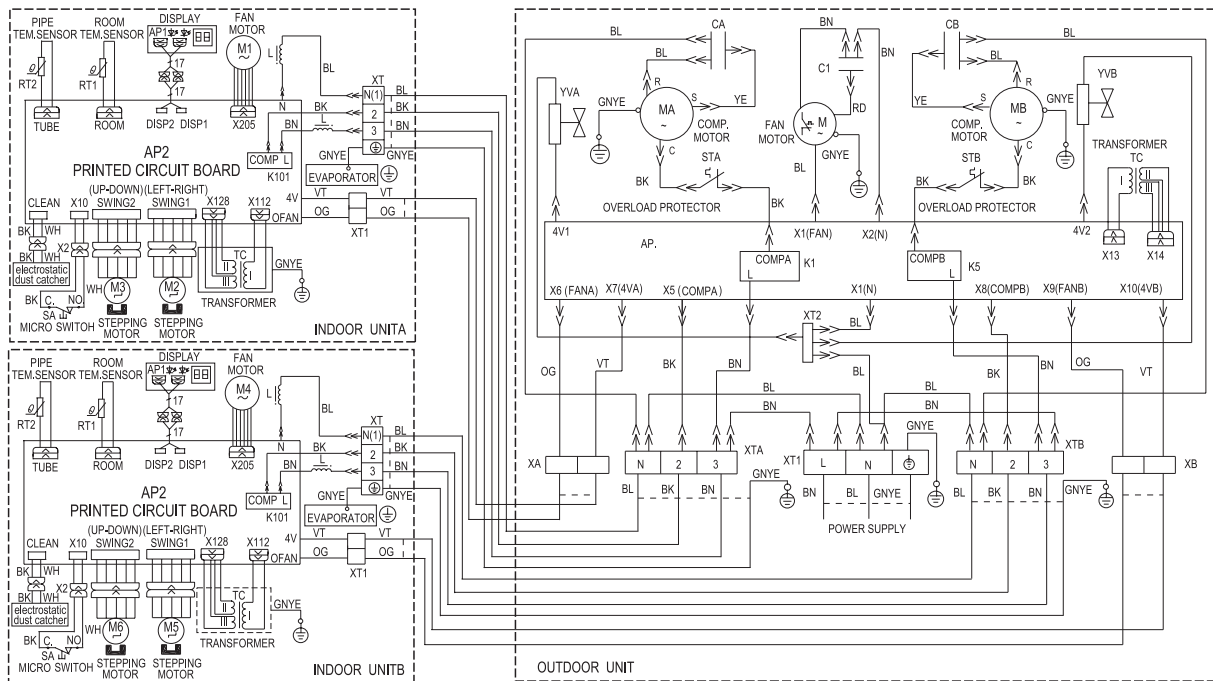

These circuit diagrams are subject to change without notice. Please refer to the ones stuck on the machines.

6 Manual of functions of remote controller and operation method

6.1 Manual of functions of remote controller

6.1.1 Temperature parameter

- ◆ The room setting temperature(T_{set})
- ◆ The room ambient temperature (T_{amb})
- ◆ The outside condenser temp. ($T_{condenser}$)

6.1.2 Fundamental functions of the system

After the power is turned on, the separation time of two consecutive starting time of the compressor should not be less than 3min. under any condition. For the first time powering on, there is not 3min. delay for the compressor. Once the compressor is started, it will not stop in 6min as the variation of the indoor temperature.

6.1.2.1 COOL mode

6.1.2.1.1 The conditions and processes of cooling

If $T_{amb} \geq T_{set} + 1^{\circ}\text{C}$, COOL mode will act, compressor and outdoor fan will run, indoor fan will run at the setting speed.

In case $T_{amb} \leq T_{set} - 1^{\circ}\text{C}$, the compressor, outer fan will stop and inner fan will be running in a setting speed;

If $T_{set} - 1^{\circ}\text{C} < T_{amb} < T_{set} + 1^{\circ}\text{C}$, the unit will keep running in the original mode.

➤ In this mode, the reversal valve will not be powered on, the setting temperature range is $16 \sim 30^{\circ}\text{C}$

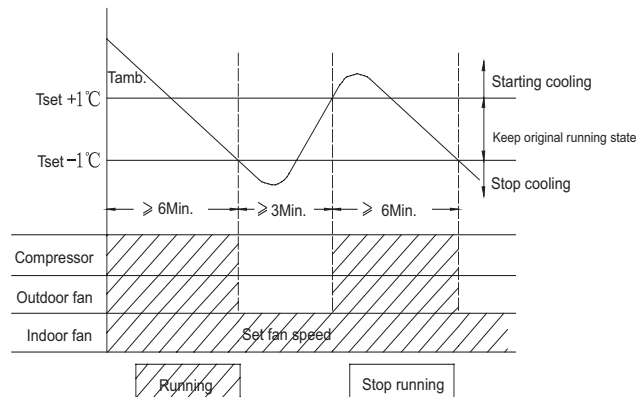

6.1.2.1.2 Protection Functions

◆ Anti-freezing protection

In case anti-freezing protection is detected by the system, the compressor and outer fan will stop running and the inner fan will run at a setting fan speed. The system will recover running 10min after compressor stops running and the antifreezing protection is released. When it is running in anti-freezing protection, to turn off the unit by the wireless remote control, that the anti-freezing mark will not be cleared.

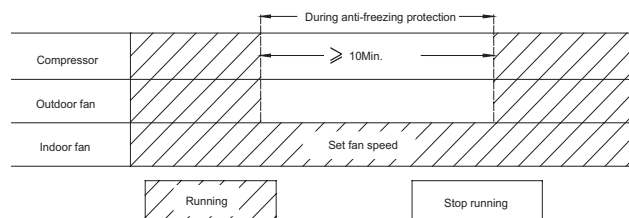

6.1.2.2 DRY Modes

6.1.2.2.1 The conditions and dry process

If $T_{amb} > T_{set} + 2^{\circ}\text{C}$, the cooling and drying modes will act, indoor fan will run at low fan speed;

If $T_{set} - 2^{\circ}\text{C} \leq T_{amb} \leq T_{set} + 2^{\circ}\text{C}$, it enters dry mode. In this case, the outer fan and compressor will stop 6min. later and will be turned on 4min. later. The dry process will be carried out as per the circulation given above, and the inner fan will keep in running at a low speed.

If $T_{amb} < T_{set}-2^{\circ}\text{C}$, the outer fan and compressor will stop running and the inner fan will keep in running at a low speed.

➤ In this mode, the reversal valve will not be powered on, the setting temperature range is $16\sim 30^{\circ}\text{C}$.

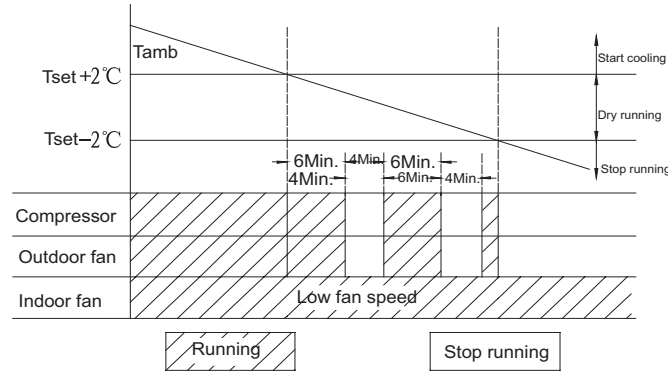

6. 1. 2. 2 Protection Functions

◆ Anti-freezing Protection

In case anti-freezing protection is detected by the system, the compressor, outer fan and indoor fan will run at low fan speed; The system will recover running 10min. after compressor stops running and the anti-freezing protection is released. When the unit is running in anti-freezing mode, if the unit is turned off by the wireless remote control, that the anti-freezing mark will not be cleared, after the unit is turned on the anti-freezing protection is still available.

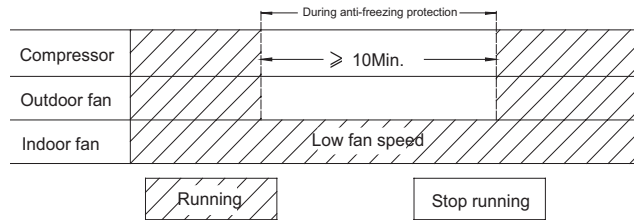

6. 1. 2. 3 HEAT Mode

6. 1. 2. 3. 1 The conditions and process of heating

If $T_{amb} \leq T_{set}+2^{\circ}\text{C}$, the system enters heating running, in this case, the reversal valve, compressor, outer fan enter simultaneously running. The indoor fan will delay at most for 2min.

If $T_{amb} \geq T_{set}+4^{\circ}\text{C}$, compressor, outer fan will stop running, but the reversal valve is still with power on, the indoor unit will run at low fan speed for 60s then will stop running.

When $T_{set}+2^{\circ}\text{C} < T_{amb} < T_{set}+4^{\circ}\text{C}$, the unit will keep running in the original mode.

➤ In this mode, the setting temperature range is $16\sim 30^{\circ}\text{C}$.

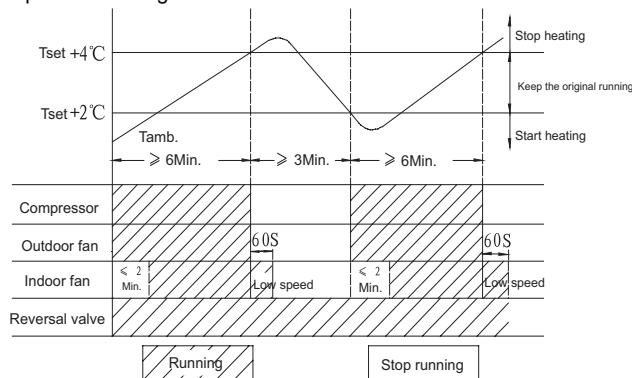

6. 1. 2. 3. 2 Conditions and processes of defrost

If frost is detected with the condenser, the system enters defrost mode. In this case, the compressor goes on running, outer fan, 4-way valve and inner fan stop running.

The running indicator flashes. After the condenser is detected with defrost completed, the outdoor fan and 4-way valve go into running at the same time, after delayed 2mins the indoor fan will run, and the compressor keeps on running mode. The running indicator stops flashing.

➤ The defrosting time is 9min for the first time power on and the defrosting time afterwards depends on the practical frost condition, the more the frost, the longer the defrosting time (Max.: 12min, min.: 3min). Exit from the defrosting mode if the frost removal is ended.

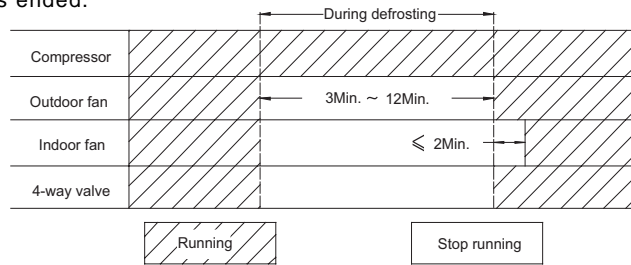

6. 1. 2. 3. 3 Protection Functions

◆ High temperature protection

If the evaporator is detected with a high temperature, the outdoor fan stops running and if the evaporator recovers to a normal temperature, the outdoor fan resumes running.

◆ Noise elimination protection

If the system is turned off by "run/stop", the reversal valve will delay for 2min before it is turned off.

6. 1. 2. 4 Swing mode

1. For this mode, indoor fan may run at high, medium, low and automatic modes (default being medium mode). The compressor, outdoor fan and 4-way will all stop running.
2. Temperature setting range at the mode is $16 \sim 30^{\circ}\text{C}$.

6. 1. 2. 5 Auto mode

For this mode, the standard cooling $T_{\text{set}}=25^{\circ}\text{C}$, standard heating $T_{\text{set}}=20^{\circ}\text{C}$;

For this mode, the system will run automatically the modes according to the ambient temperature (cooling, dry, heating and air supply), with the protection function same as the cooling/heating mode (remarks: 30s delay protection for mode change over).

For the AUTO mode in cooling and heating mode: In AUTO mode, when to change over the heating mode to other mode, the reversing valve will power off for 120s.

6. 1. 3 Other control

6. 1. 3. 1 Sleep function

For cooling or dry running, after the sleep setting for one hour, the setting temperature will be increased 1°C . 2hr later, the setting temperature will be raised for another 1°C . Within 2hr, the temp. increased 2°C . Indoor fan will run at the setting fan speed.

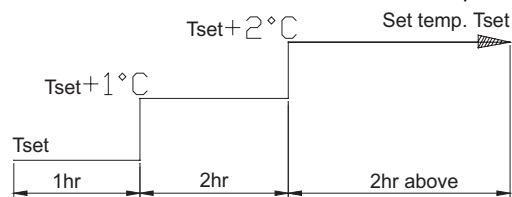

For heating running, after the sleep setting for one hour, the setting temperature will be decreased for 1°C . 2hr later, the setting temperature will be decreased for another 1°C . Within 2hr, the temp. decreased 2°C . Indoor fan will run at the setting fan speed.

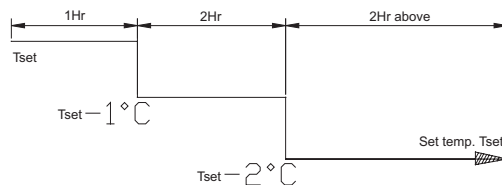

In FAN mode and AUTO mode, the setting temp. will not change.

6. 1. 3. 2 Swing motor control

6. 1. 3. 2. 1 Swing Up/Down control

After the power is turned on the swing Up/Down motor will firstly rotate the guide blade counter clockwise to 0 position to close the air outlet vent. If there is no swing function cooling and heating function setting, the up and down swing louver will be rotated to D position; in other state setting, the swing guide blade will be rotated clockwise to horizontal position, the outlet air vent L position. If there is swing function setting when the system is turned on, the swing guide blade will be swinging from L to D. The swing guide blade has 7 kinds of swing modes: swinging among positions A, B, C, D, L to D, stopping at any position from L to D (the inclusive angle between L and D being an equal angle) with the swing guide blade stopping at 0 position when the system is turned off. The swing act is only available when the swing command be set up and the indoor fan is running.

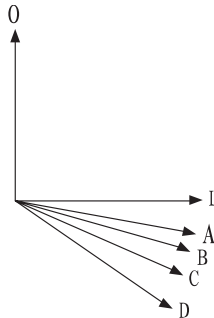

6. 1. 3. 2. 2 Swing Left/Right control

After the power is turned on the swing Left/Right motor will drive the guide blade left and right to middle position. If there is no left/right swinging, the swing guide blade will stop at the middle position and will not move. If there is swing setting by a remote controller, swing guide blade will stop at the angle designated by the remote controller. For left/right swing, there are 7 swing modes: left side, second to the left side, middle, second to the right side, right side, left/right swing and stop positions (the inclusive angle between left and right swing positions being an equal angle). If there is left/right swing setting when the system is turned on, the left/right swing motor will drive the guide blade to swing left/right and the blade will stop at the present position. The left/right swing will be at the original position when the system is turned off. The swing act is only available when the swing command be set up and the indoor fan is running.

6. 1. 3. 3 Air cleaning function (electrostatic dedusting unit has no this function)

Press the "Air cleaning" button at the wireless remote control to start, press the button once more to turn it off. "Air cleaning" controls electrostatic dedusting. When the "Air cleaning" signal be received, after the electrostatic dedusting device stopped for 1min, should start the electrostatic dedusting device right away.

Note: The starting of electrostatic dedusting device should be after the indoor fan run for 5s later.

6. 1. 3. 4 Display function

The contents displayed by displayer including: Temp., Heating, Cooling, Dry, Fan, Swing, Fan speed, Sleep, Power indicator, Defrosting.

6. 1. 3. 4. 1 Double 8 power and mode display

After the power is turned on, the display picture is lit completely for 1.5s. At the same time the buzzer releases a pleasing sound. After that, only the green power indicator is lit. The power indicator is distinguished when the system is turned on with the remote controller. At the same time, the running mode picture of present setting will be displayed being respectively heating, cooling, dry and ventilation, and if the remote controller setting being automatic mode, the present running mode will be indicated. The light indicates the temperature and fan speeds (the extreme inner one being the low speed, the middle one being the medium speed, the extreme outer one being the high speed and all the three being lit for the automatic speed). If it is a sleep function setting, only the pictures for sleep and running are given. After the light is off, only the running mode picture is lit. For off mode, only the power indicator picture is lit. The swing indicator will be lit when there is swing running, otherwise, it is distinguished. For the system with power on, the digital tube will indicate the present setting temperature (setting temperature range being $\pm 16^{\circ}\sim 30^{\circ}\text{C}$).

6. 1. 3. 4. 2 Working state and malfunction indicate

- Defrosting indicator: Entering into the defrosting it will lit, when quit the defrosting it will extinguish; (When defrosting, the indicator will flash);
- Defrosting indicator: At this time, the temp. will display "DF" by double 8 digital tube;
- Anti-cool wind indicator: When entering into anti-cool wind, the temp. will display "CP" by double 8 digital tube;
- High temp. prevention indicator: Due to the high temp. then stop the outer fan, the temp. will display "HP" by double 8 digital tube, the outdoor fan resume to work and the indicator will extinguish.

6. 1. 3. 5 Timing function

6. 1. 3. 5. 1 Timer on

If the system is at off mode and the time setting is up for the time on, it will start timing since the controller send the signal, when the time has arrived that the unit will turn on the unit automatically;

6. 1. 3. 5. 2 Timer off

If the system is at on mode and the time setting is up for the time ff, it will start timing since the controller send the signal, when the time has arrived that the unit will turn off the unit automatically;

The time could be set as the multiples of 0.5hr, the max. is 24hr.

6. 1. 3. 6 Buzzer

The buzzer will deliver a pleasing sound when the controller is powered on or receives a signal from the remote controller.

6. 1. 3. 7 Auto button

When the button is pressed down, the system will be running at auto mode. The indoor fan will be running at auto mode. The ON/OFF light button is then turned on, up/down and left/right swinging are set up simultaneously at running mode. Press the button once more to turn off the system.

6. 1. 3. 8 Auto fan speed control

At this mode, the indoor fan will select according to the ambient temperature three speeds, i.e. high, medium and low speeds. In auto fan mode, it should be 3minutes and 30seconds for fan speed change over

6. 1. 3. 9 Memory function

Memory contents: Modes, Left and right swing, Up and down swing, Electrostatic dedust, Light, setting temp, setting fan speed.

After powered off, when power on, the unit will automatically turn on and run at the contents by memory.

There isn't timing function be set up by wireless remote control at the last time, that the system will memorize the last command by wireless remote control, and it will run at the command.

If there is timing function be set up by the wireless remote control at the last time, before the timing arrived the system is powered off, after powered on, the system will memorize the timing function of the last wireless remote control command, that the timing will recalculate when it repowered on.

If there is timing function be set up by the wireless remote control at the last time, if the timing arrived, if the system powered off after the timer on or timer off act, when repower on, the system will memorize and run at the state before powered off, that the timing function will not act.

The cooling only type unit doesn't receive the heating signal by wireless remote control, but it receives the heating and turn off signal. At unit off, the cooling only unit received the heating and timer on signal by wireless remote control, when the timing arrived, it will run at the state before unit turn off.

7 Disassembly Procedures

7.1 Disassembling process of indoor unit

Operation procedures/pictures

7.1.1 Disassemble the front panel

Pull the panel open. Firstly, screw off the screw fixing the top cover of the electric box and remove the top cover. Then pull away the connection terminal. Pull the panel outward with force along the groove fixing the panel of the panel body to remove the panel as shown in Fig.7-1

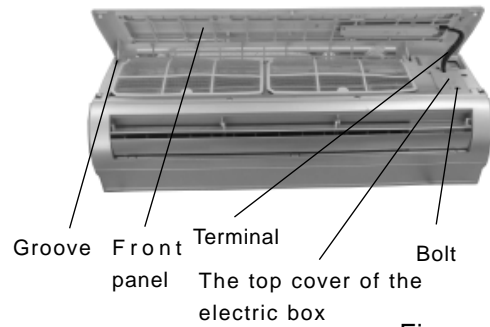

Fig. 7-1

7.1.2 Disassemble filter

Push the filter inward and then upward to remove the filter as shown in Fig.7-2;

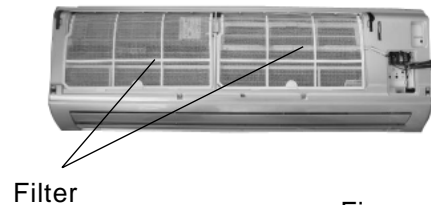

Fig. 7-2

7.1.3 Disassemble the guide louver

Bend the guide louver so that the movable lock of guide louver is released to remove the guide louver as shown in Fig.7-3

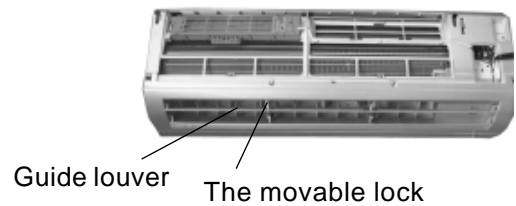
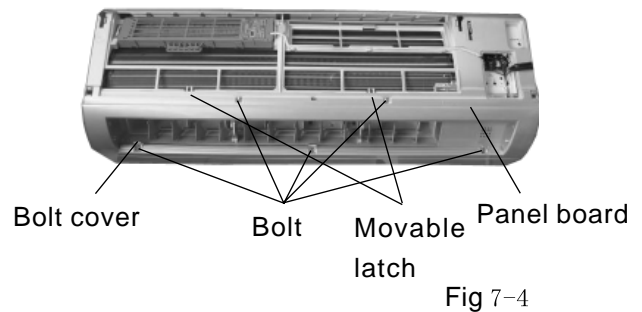

Fig 7-3

Operation procedures/pictures

7.1.4 Disassemble the panel board

Open the 3 screw covers at the panel board and screw off 5 screws. Pull out the movable latch at the panel board with hand and then pull it backwards to disassemble the panel board as shown in Fig.7-4



7.1.5 Disassemble water tray

Screw off the fixing screws fixing the water tray with a screw driver, and pull out the terminal board of the step motor. Pull upwards the water tray. Remove the water tray as shown in Fig. 7-5

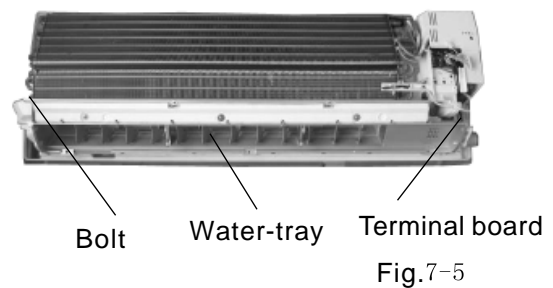

7.1.6 Disassemble electric box

Open three movable latches with hand and then pull them upward to remove the cover of electric box as shown in Fig.8-6.

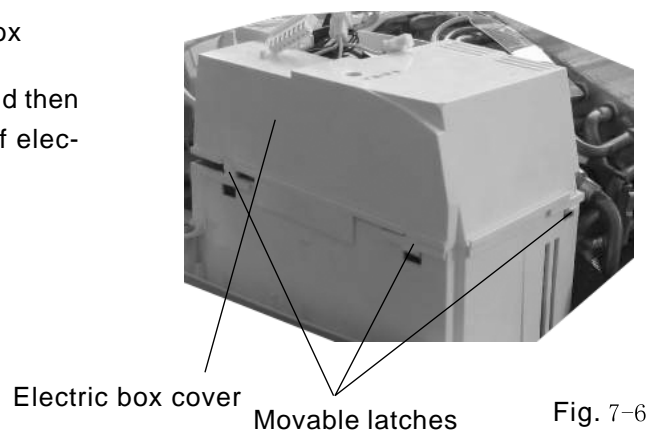

Operation procedures/pictures

7.1.7 ||| Disassemble electric box

Remove the grounding wire of the evaporator, and remove the temperature sensor for the pipe. Remove the connection lines for the indoor motor. Screw off the screws fixing the electric box with a screw driver. Remove the electric box as shown in Fig. 8-7

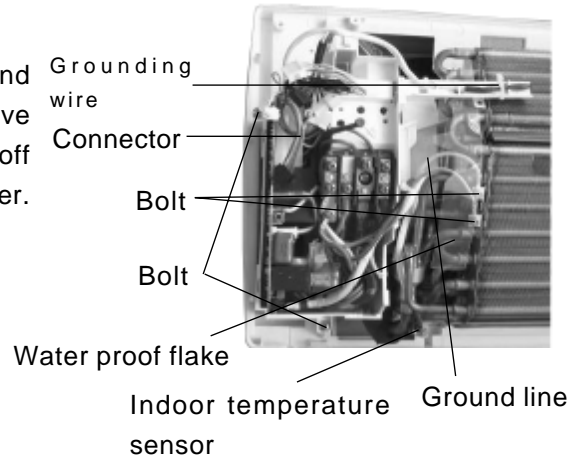

Fig.7-7

7.1.8 ||| Disassemble evaporator

The lower rear clamp plate can be removed by just screwing off one screw with a screw driver. Screw off two screws at both left/right sides of the evaporator and take out the evaporator with hand, so that the side board catch of the evaporator is disengaged from the groove. Remove the evaporator carefully and take care to protect the connection pipe as shown in Fig.7-8,7-9,7-10.

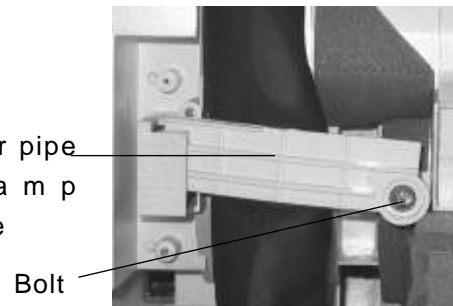

Fig.7-8

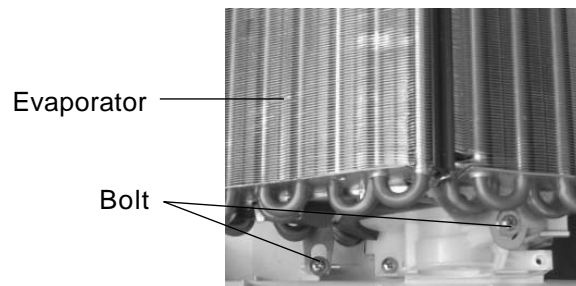
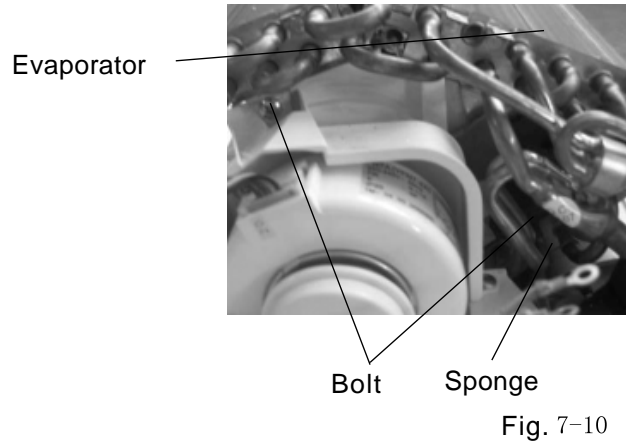

Fig 7-9

Operation procedures/pictures



7.1.9 Disassemble motor

Screw off the two screws fixing the motor pressure plate with a screw driver and remove the pressure plate. Screw off the three fixing screws at the axle sleeve and remove the motor as shown in Fig.7-11,7-12.

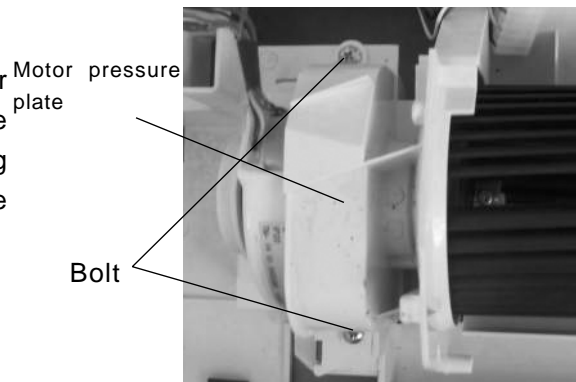
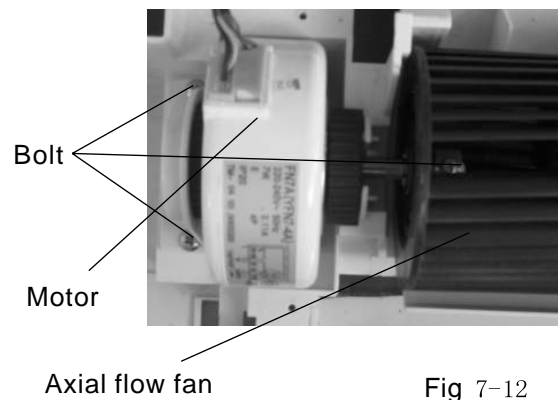

Fig 7-11



Operation procedures/pictures

7. 1. 10 ||||| Disassemble cross flow fan

Screw off one screw fixing the bearing rubber gasket with a screw driver and remove the bearing rubber gasket. In this case, the cross flow fan can be removed as shown in Fig.7-13.

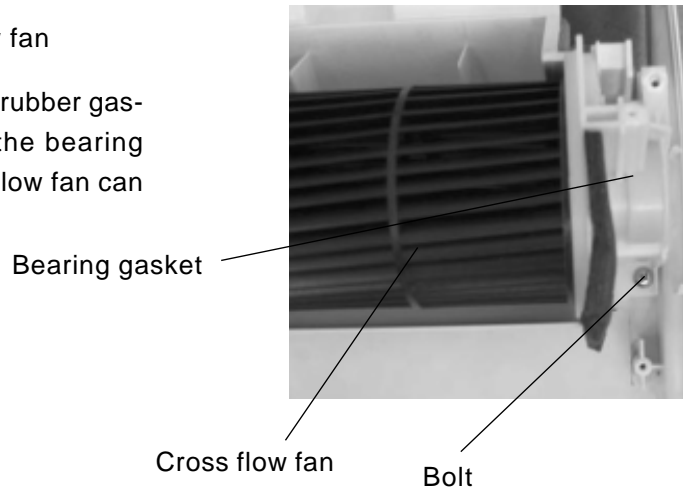

Fig.7-13

7. 1. 11 ||||| Auxiliary electric heater

(Note: only existing in cooling/heating units)

Screw off 2 screws fixing the auxiliary electric heater with a screw driver as shown in Fig.7-14.

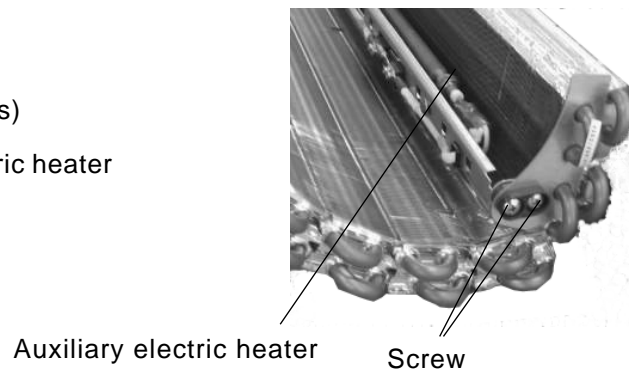

Fig.7-14

7.2 Disassembly Procedures of the outdoor unit

Operation procedures/pictures

7.2.1 Disassemble the top cover

Screw off one screw fixing the handle with a screw driver and remove the handle after pushing downward with force.

Screw off three screws around the top cover and pull upward to remove the top cover as shown in Fig.7-15

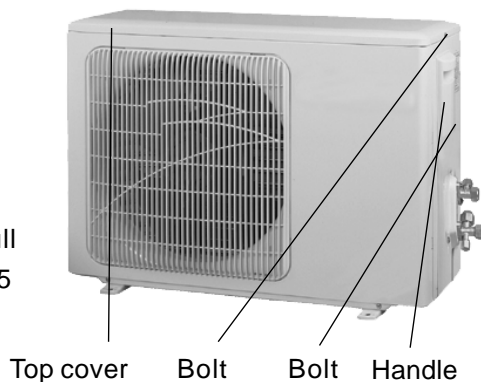

Fig. 7-15

7.2.2 Remove the net cover

Screw off 4 tapping screws at the rear side board, and the valve frame bottom plate and condenser side board. Remove the net cover as shown in Fig.7-16

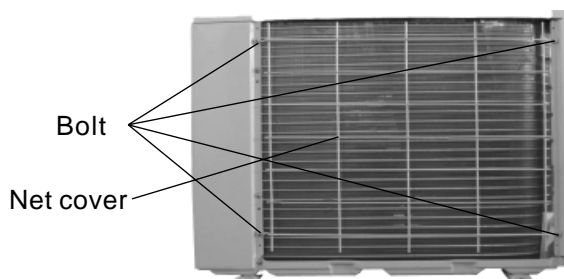

Fig 7-16

7.2.3 Disassemble panel assembly

Screw off 5 tapping screws at the rear side board and the valve frame bottom plate and condenser side board. Remove the front panel assemble as shown in Fig.8-17.

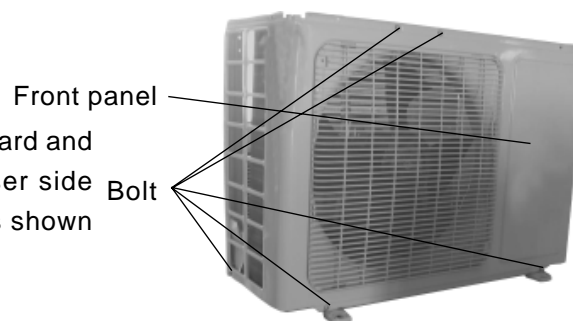

Fig 7-17

Operation procedures/pictures

7.2.4 Disassemble electric device installation board

Screw off the 3 screws fixing the electric device installation board, and pull out the inserting contacts for leads of compressor and fan motor, and remove the electric device installation board as shown in Fig.7-18.

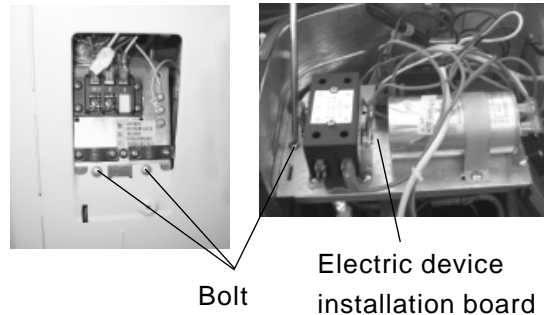

Fig. 7-18

7.2.5 Disassemble right side plate assembly

Screw off the 5 screws at the rear side plate to remove the right side plate assembly as shown in Fig.7-19.

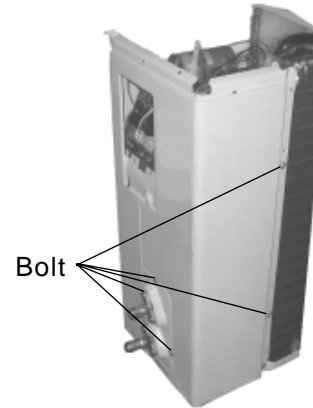

Fig.7-19

7.2.6 Disassemble axial flow fan

Loosen the fixing nut with a spanner, remove the nut, spring washer and flat washer. Remove the lower axial flow fan with force as shown in Fig.7-20.

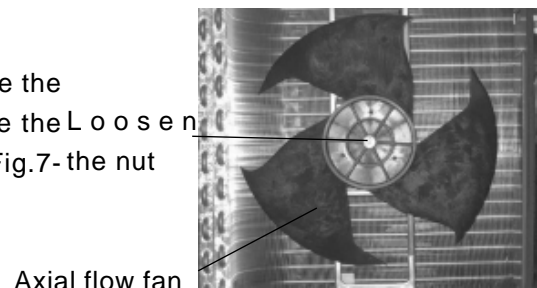

Fig.7-20

Operation procedures/pictures

7.2.7 Disassemble motor and motor support

Screw off the 4 tapping screws fixing the motor and remove the motor. Screw out the 2 tapping screws and remove the motor support by pulling upward as shown in Fig.7-21.

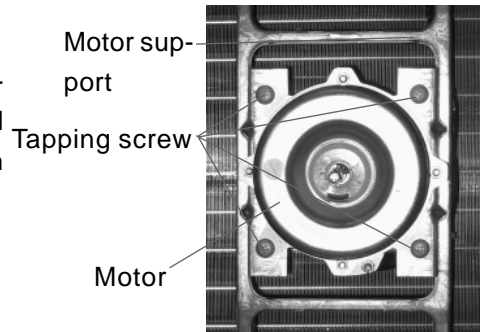

Fig.7-21

7.2.8 Disassemble 4-way valve (Only existing in cooling/heating unit)

Screw off the fixing nuts for the fixing the solenoids of 4-way valve and remove the solenoid. Wrap the 4-way valve with wet gauze and solder off the 4 soldering points of 4-way valve, remove the 4-way valve. It is recommended to solder as quickly as possible and the cotton gauze should always be wet. Make sure not to burn the leads of compressor as shown in Fig.7-22. (Remarks: prior to disassembling any pipe component or compressor, it should be sure that no cooling refrigerant left inside any more.)

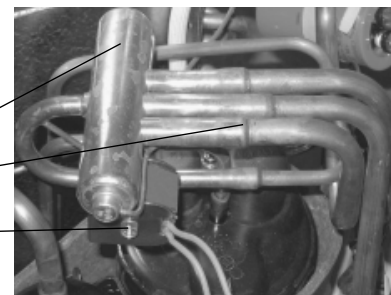

Fig7-22

7.2.9 Disassemble liquid divider assembly

Solder off the soldering points connecting the liquid divider assembly and other pipes as shown in Fig.7-23.

Liquid divider assembly



Fig. 7-23

Operation procedures/pictures

7.2.10 ||||| Disassemble big and small valves

Screw off the 2 screw bolts fixing the big valve and solder off the soldering point connecting the big valve and the gas returning pipe. Remove the big valve (Remarks: It is recommended to wrap the big valve with wet gauze completely when soldering off the soldering points to prevent the valve body from being damaged by high temperature). Screw off the 2 screwed bolts fixing the small valve, and solder off the soldering point connecting the small valve and the cross type pipe. Remove the small valve as shown in Fig.7-24.

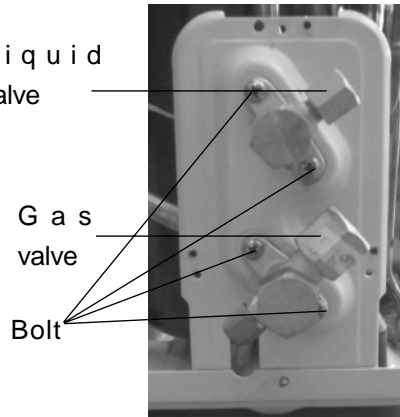

Fig 7-24

7.2.11 ||||| Disassemble the compressor

Screw off the 3 washer nuts at the bottom legs of the compressor (Remarks: requiring drainage of cooling refrigerant first.) Solder off all the soldering points of sucking/discharging pipes for the compressor, and remove carefully the piping. Remove the compressor as shown in Fig.7-25.

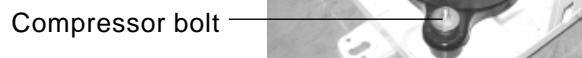

Fig.7-25

7.3 Disassembly Procedures of the outdoor unit

It is applicable to one to two outdoor unit

7.3.1 Remove the front side plate

Screw off the screws which fixing on the front side plate, then slide down, then can disassemble the front side plate. As shown in Fig. 7-26.

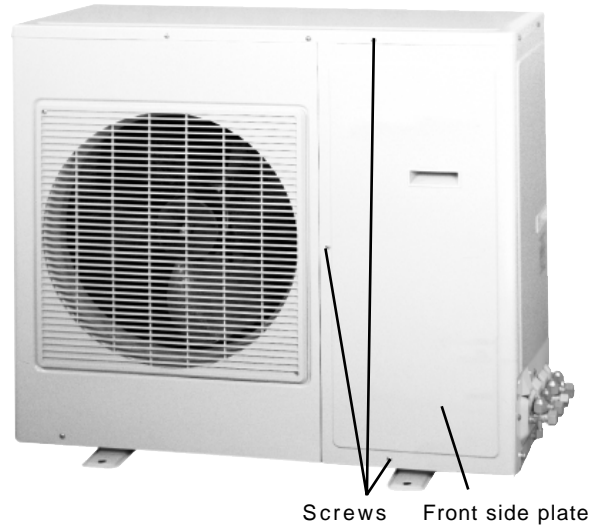

Fig. 7 - 26

7.3.2 Disassemble the top cover

Screw off the screws which fixing on the top cover, then could disassemble the top cover. As shown in Fig.7-27;

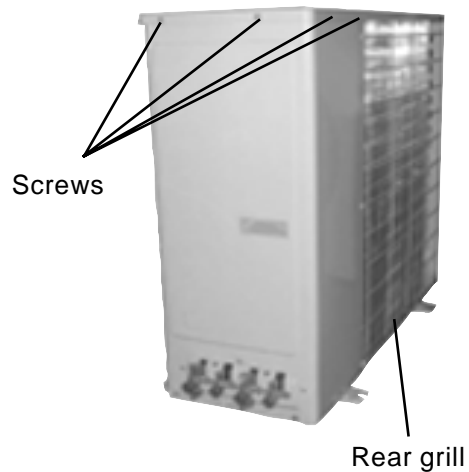

Fig.7 - 27

7.3.3 Disassemble the rear grill

Screw off 4pcs screw which fixing the rear grill, then could disassemble the rear grill. As shown in Fig. 7-28;

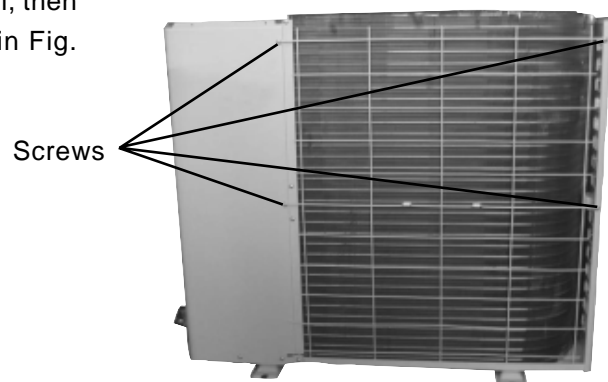

Fig.7 - 28

Operation procedures/pictures

7.3.4 Disassemble the front panel

Screw off 8 tapping screws which fixing the front panel, then can disassemble the front panel. As shown in Fig.7-29.



Screws

Fig.7 – 29

7.3.5 Disassemble the electric box

Pull out the lead out insert of fan motor, then pull out the connection wire of two compressors, then screw off 2 tapping screws of electric box, then disassemble the electric box. As shown in Fig.7-30;

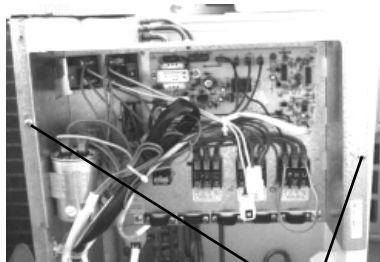

Screws

Fig. 7 – 30

7.3.6 Disassemble the rear side plate

Loosen 8pcs screw which fixing the rear side plate, then can disassemble the rear side plate. As shown in Fig.7-31;



Screws

Screws

Fig.7 – 31

Operation procedures/pictures

7.3.7 ||| Disassemble axial flow fan

Loosen the fixing nut with a spanner, remove the nut, spring washer and flat washer. Remove the lower axial flow fan with force as shown in Fig.7-32;

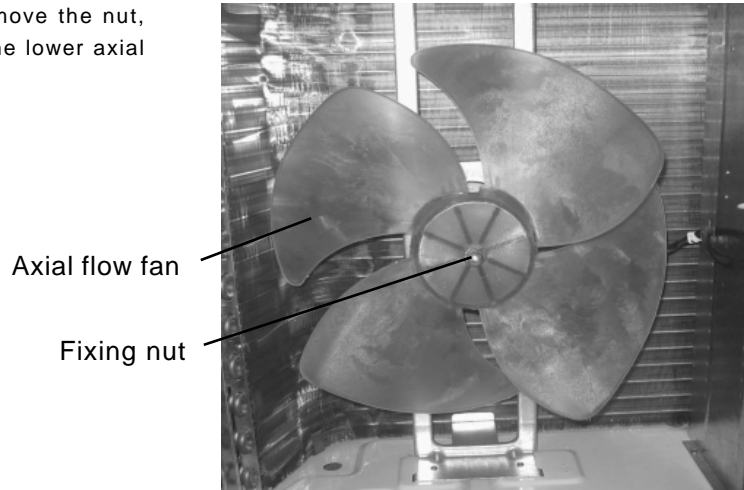

Fig.7 – 32

7.3.8 ||| Disassemble motor and motor support

Screw off the tapping screws and remove the motor. Screw out 2 tapping screws and remove the motor support by pulling upward as shown in Fig. 7-33.

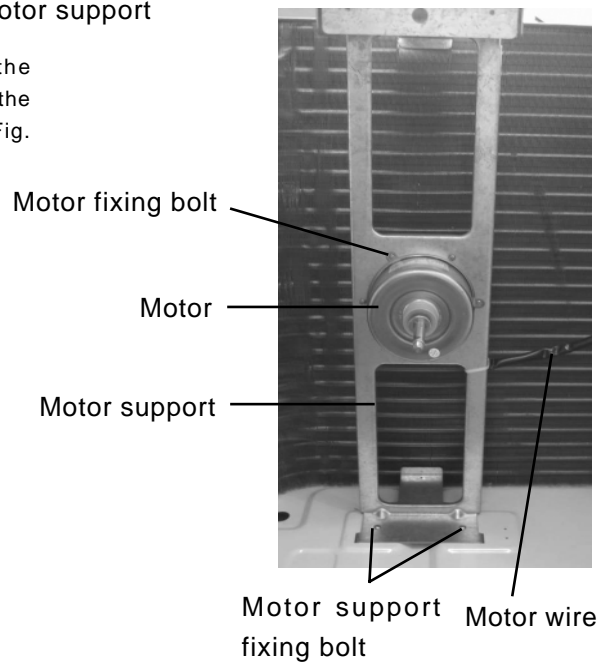

Fig. 7 – 33

Operation procedures/pictures

7.3.9 ||||| Disassemble 4-way valve

Screw off the fixing nuts for the fixing the solenoids of 4-way valve and remove the solenoid. Wrap the 4-way valve with wet gauze and solder off the 4 soldering points of 4-way valve, remove the 4-way valve. It is recommended to solder as quickly as possible and the cotton gauze should always be wet. Make sure not to burn the leads of compressor as shown in Fig.7-34;

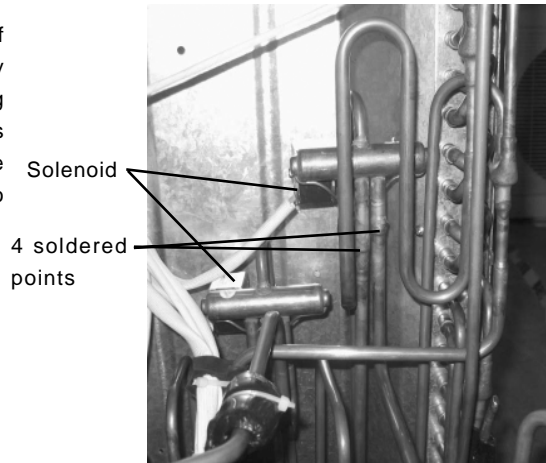
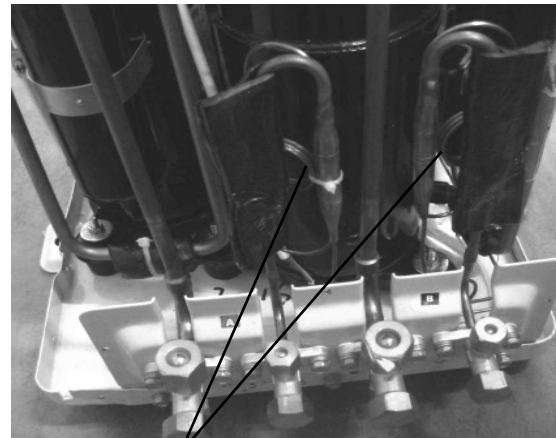

Fig. 7 — 34

7.3.10 ||||| Disassemble the capillary

Unsolder 4pcs soldered point of 2pcs capillary sub-assy and small valve as well as condenser outlet pipe, take off the capillary sub-assy. As shown Fig.7-35;



Capillary

Fig. 7 — 35

7.3.11 ||||| Disassemble the big valve and small valve

Screw off bolts fixing the valves, then unsolder the connection pipe which connected with the valves. Then can disassemble the valves. (Note: when soldering the soldered points, it is necessary to use the wet cloth to wrap the valves, in order to avoid the valves be damaged.) As shown in Fig 7-36;

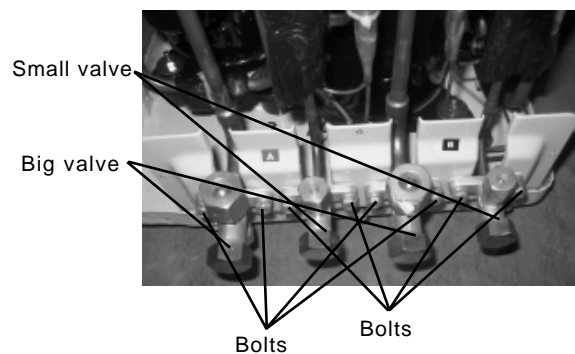

Fig.7 — 36

Operation procedures/pictures

7.3.12 Disassemble the compressor

Screw off the 6 washer nuts at the bottom legs of two compressor (Remarks: requiring drainage of cooling refrigerant first.) Solder off all the soldering points of sucking/discharging pipes for the compressor, and remove carefully the piping. Remove the compressor as shown in Fig.7-37.



Washer nuts

Fig. 7 – 37

8 Explosive view and list of parts for indoor unit

8.1 Explosive view of parts for indoor unit

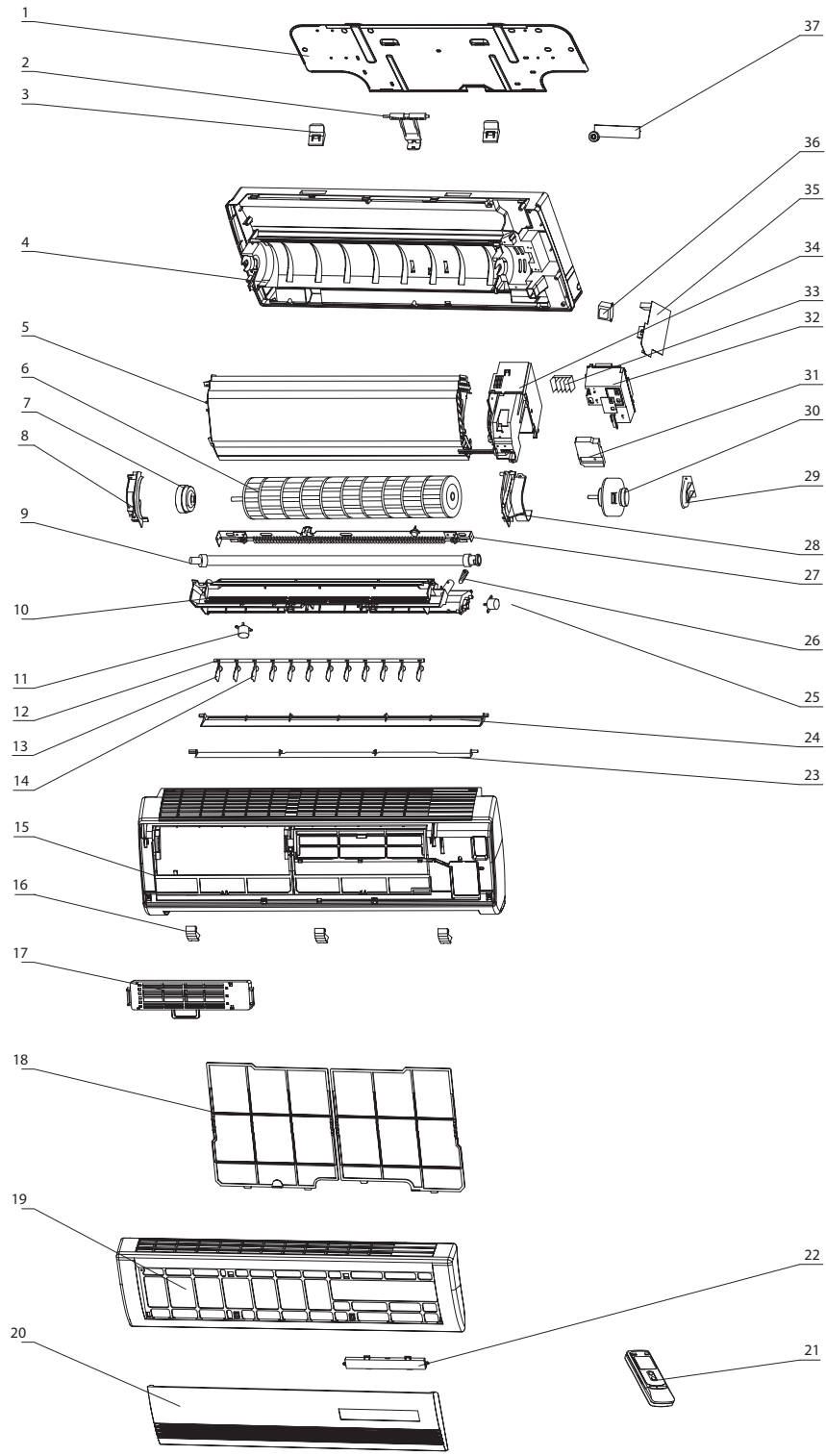

8.2 Parts list of indoor unit

No	Description	Part Code	Qty
		ASH-09AQ	
1	Wall Mounting Plate	01252384	1
2	Pipe Clamp	26112425	1
3	Hook	26272421	1
4	Rear Case	22202037	1
5	Evaporator Assy	01032082	1
6	Cross Flow Fan	10352405	1
7	Ring of Bearing	76712015	1
8	Left clamp of motor	261124281	1
9	Drainage Pipe	05232411	1
10	drainpanassy	20182034	1
11	Motor MP24CA	15212106	1
12	Swing link	105824393	1
13	Swing Louver	10512046	2
14	Swing Louver	10512047	10
15	Front Case	20002301	1
16	Screw Cover	242524408	1
17	Static dust catcher	11012201	1
18	Filter	111224442	2
19	Front Panel	20002301	1
20	Panel	20002305	1
21	remotecontroller	30515037	1
22	displayboard	305452081	1
23	swinglouver	10512050	1
24	connecter	10512052	1
25	Motor MP24GA	15212102	1
26	drainpanassy stuff	76712005	1
27	Electric Heater 600W	/	/
28	Right Motor Clamp	26112429	1
29	Motor Bearing Holder	26152423	1
30	Motor FN8H	15012051	1
31	Electric Box Plate	20122009	1
32	Electric Box Cover	20102123	1
33	Terminal Board GTT4A3A	42011240	1
34	Electric box	20102108	1
35	mainboard	30035443	1
36	Transformer SC28D	43110194	1
37	Pipe Clamp	24242004	1

The above data are subject to change without notice.

No	Description	Part Code	Qty
		ASH-13AQ	
1	Wall Mounting Plate	01252384	1
2	Pipe Clamp	26112425	1
3	Hook	26272421	1
4	Rear Case	22202037	1
5	Evaporator Assy	01032150	1
6	Cross Flow Fan	10352005	1
7	Ring of Bearing	76712015	1
8	Left clamp of motor	261124281	1
9	Drainage Pipe	05232411	1
10	drainpanassy	20182034	1
11	Motor MP24CA	15212106	1
12	Swing link	105824393	1
13	Swing Louver	10512046	2
14	Swing Louver	10512047	10
15	Front Case	20002301	1
16	Screw Cover	242524408	1
17	Static dust catcher	11012201	1
18	Filter	111224442	2
19	Front Panel	20002303	1
20	Panel	20002305	1
21	remotecontroller	30515037	1
22	displayboard	305452081	1
23	swinglouver	10512050	1
24	connecter	10512052	1
25	Motor MP24GA	15212102	1
26	drainpanassy stuff	76712005	1
27	Electric Heater 600W	/	\
28	Right Motor Clamp	26112429	1
29	Motor Bearing Holder	26152423	1
30	Motor FN8H	15012062	1
31	Electric Box Plate	20122009	1
32	Electric Box Cover	20102123	1
33	Terminal Board GTT4A3A	42011240	1
34	Electric box	20102108	1
35	mainboard	30035443	1
36	Transformer SC28D	43110194	1
37	Pipe Clamp	24242004	1

The above data are subject to change without notice

8.3 Explosive view of outdoor unit

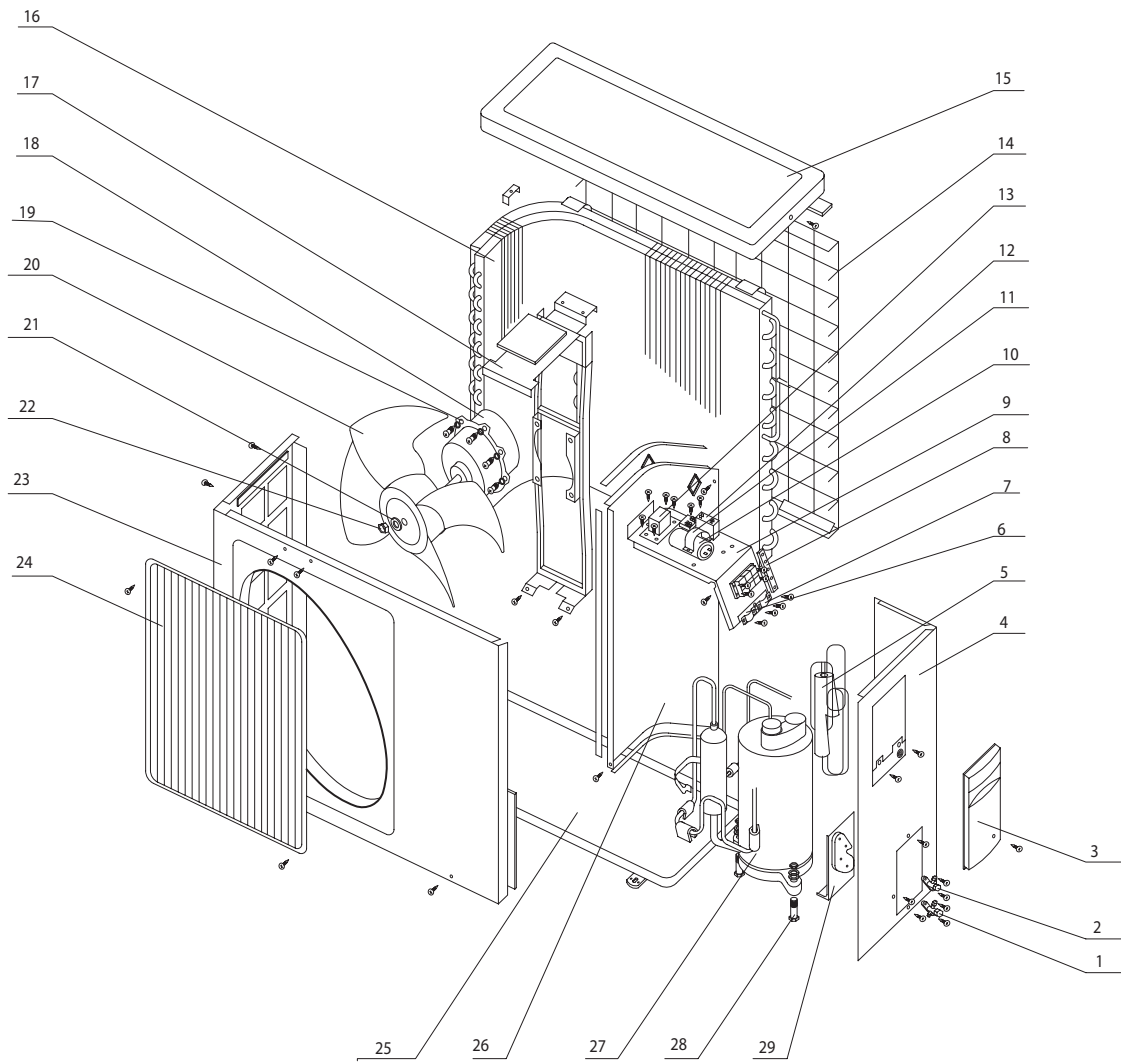

8. 4 Parts list of outdoor unit

No	Description	PartCode	Qty
		ASH-09AQ	
1	valve 1/4"	07100003	1
2	valve 3/8"	07100005	1
3	handle	26233433	1
4	right side plate assy	01302004	1
5	capillary assy	03003871	1
6	Isolation WasherD	70410523	1
7	Wire Clamp	71010103	1
8	terminal board	42011241	1
9	electric box assy	01413425	1
10	compressor capacitor	33000017	1
11	Capacitor clamp	02143401	1
12	Capacitor 2.5uF/450V	/	1
	Capacitor 2uF/450V	33010025	
13	terminal board	42011103	1
14	Rill grill	01473030	1
15	top cover	01253443	1
16	condenser	01133392	1
17	motor support	01703391	1
18	Motor FW25K	/	1
	Motor FW30K	15013067	
19	Screw ST4.8x16	70140165	4
20	axial flow fan	10333413	1
21	Washer 6	70410252	1
22	Nut M6	70310132	1
23	front plate	015330121	1
24	front grill	22413001	1
25	metal bas	01213429	1
26	clapboard assy	01233417	1
27	compressor	00100368	1
28	Nut with washer M8	70310014	3
29	valve support	01713043	1

The above data are subject to change without notice.

No	Description	Part Code	Qty
		ASH-13AQ	
1	valve 1/2"	07100006	1
2	valve 1/4"	07100003	1
3	handle	26233433	1
4	right side plate assy	01302004	1
5	capillary assy	03003568	1
6	Isolation Washer C	70410523	1
7	Wire Clamp	71010103	1
8	terminal board	42011241	1
9	electric box assy	01413425	1
10	compressor capacitor	33000017	1
11	Capacitor clamp	02143401	1
12	Capacitor 2.5uF/450V	33010026	1
13	terminal board	42011103	1
14	Rill grill	01473030	1
15	top cover	01253443	1
16	condenser	01133392	1
17	motor support	01703391	1
18	Motor FW25K	150130671	1
19	Screw ST4.8x16	70140165	4
20	axial flow fan	10333413	1
21	Washer 6	70410252	1
22	Nut M6	70310131	1
23	front plate	015330121	1
24	front grill	22413001	1
25	metal base	01213429	1
26	clapboard assy	01233417	1
27	compressor	00100378	1
28	Nut with washer M8	70310014	3
29	valve support	01713043	1

The above data are subject to change without notice.

9 Installation instructions

9.1 Selection of Installing Location

1 Indoor unit

- The air inlet and outlet vent should be far away from obstruction so that air can be blown to the entire room.
- Select the place where it is easy to drain condenser or easy to connect with outdoor unit;
- Be far away from heat resource, steam and inflammable gas.
- Select the place where it is possible to stand the weight of indoor unit without increasing the running noise and vibrations.
- Ensure there should be enough space for maintenance or repair, distance between indoor unit and floor should be over 2m.
- Place the units to where 1m or more away from TV, Hi-fi and other appliances.
- Place the unit to where air filter may be taken out easily.
- Ensure the installation of indoor unit meet the requirements in installation dimension diagram.

2 Outdoor unit

- It should be located at a place not affecting the neighbors with noise and air flow generated by discharging.
- Good ventilation should be ensured for the outdoor unit.
- No obstacles affecting the air inlet/outlet of the set should be allowed around the outdoor unit
- The installation location should be able to bear the weight and vibration of outdoor unit and should enable the safe installation.
- It should be installed in a location free from leakage of inflammable or corrosive gas.
- It is required that the installation of outdoor unit should meet the requirements of the attached diagram for installation.

Remarks:

Failure may occur if the air conditioners are installed at the locations as stated below. Please consult with the service center of SINCLAIR if it is unavoidable to install them at such locations.

- Location full of engine oil
- Salty and alkali areas at the sea side
- Location with sulfa gas (such as sulfa warm water spring)
- Locations with RF facilities, such as radio equipment, electric soldering machine and medical equipment.
- Location with special ambient condition.



3 Circuit wiring

1. Installation is required to follow the regulations for wire connection of National Standards.
2. It is required that the rated voltage should be used and the diameter of special power line for air conditioner should be big enough.
3. The grounding wire should be reliable and should be connected to the special grounding device of the building by a specialist. Installed in the fixed lines, the leakage protection switch and air breaker should be with enough capacity (as shown in the table below). The air breaker should be at the same time having magnetic disengaging function so that short circuit and overload protection may be provided for the system.

Type of system	Capacity of air breaker	Min. cross section of ground wire	Min. cross section of power line for air conditioner
ASH-09AQ	10A	1.0mm ²	1.0mm ²
ASH-13AQ	16A	1.5mm ²	1.5mm ²
ASH-09+12AQ	16A	2.5mm ²	2.5mm ²

3 Grounding requirements

1. It is required to use reliable grounding measure since the air conditioner is an industrial class electric appliance.
2. The yellow and green double color line is the grounding wire inside the air conditioner and should not be used for other purpose. It is not allowed to cut it down.
3. The grounding resistance should meet the requirements of National Standards GB17790.
4. The power supply of the users should be provided with a reliable grounding. Please do not connect the grounding wire to the locations as given below:
 - ① Running water pipe
 - ② Gas pipe
 - ③ Drainage pipe
 - ④ Other locations where they are considered to be not reliable.

9.2 Install Indoor Unit

1 Install the wall mounted type unit

- Measure the horizontal position by a setting on method; Since the drainage pipe is on the left side adjust the rear plate to make its left side a little bit lower.
- Fix the hanging plate with screw on the wall.
- After installing the rear plate, pull it by hand to check if it is firm enough. The hang plate should support the weight of an adult (60kg), and the weight shared by every bolt for steady should be fairly even.

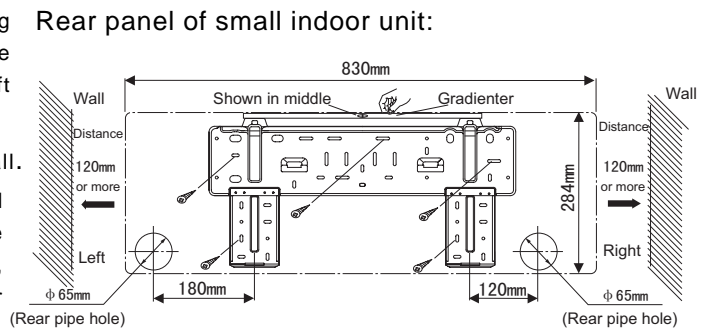

Fig.9-1

2 Install the piping hole

- After determination of the location hole for auxiliary pipe (Fig.9-1), drill a hole inclined outward ($\phi 50$).
- Insert the piping-hole sleeve into the hole to prevent the connected piping and wiring from being damaged when passing through the hole.

3 Install drainage hose

- Drainage hose must be placed at a downward slant for smooth drainage.
- Do not twist, bend or heave the drain hose or immerge its end into water (as shown in Fig. 9-2)
- The prolonged drainage hose must be wrapped by heat insulation material when going through indoor unit.

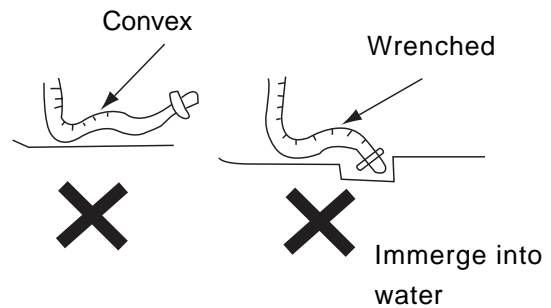

Fig.9-2



4 Install connecting pipe

Connect the connecting pipe with the 2 leading pipes from indoor unit correspondingly, tighten joint nuts on connecting pipe. (please refer to the install the connecting pipe)

Notes:

- Connect the connecting pipe with indoor unit first, and then outdoor unit.
- Be careful when bending connecting pipe, avoid damaging it.
- Don't tighten the joint nut too much, or leakage would occur.

5 Electric wiring

- Open the panel upward;
- Screw off the fixing screw of cover plate for wiring terminals , as shown in Fig.9-3 (a);
- Lead the power connecting wire through bottom case and wire hole at bottom of electric box from below upward.
- For one to one unit to connect the blue power connecting line to terminal “N(1)” at the terminal box and the brown line, to “2”, the yellow/green (ground line) to ground to  as shown in Fig.9-3(b); For one to two unit to connect the blue power connecting line to terminal “N(1)”, the red line to “2”, brown line to “3”, the yellow/green (ground line) to ground to  as shown in Fig. 9-3(d); Press tightly the power lines with the line pressure groove turned forward at the connection bar in the electric box.
- As to the heat pump, the signal control line is connected to indoor unit with connector as shown in Fig.9-3(c),(d);
- Recover the front panel.

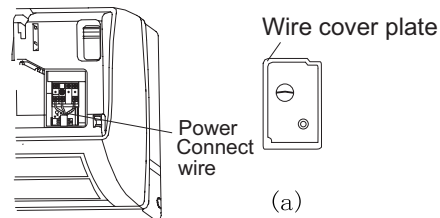
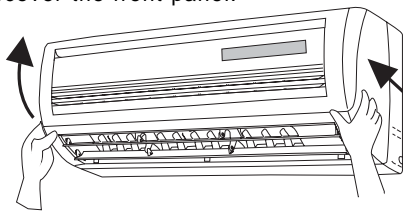

Electric wiring diagram for one to one indoor unit:

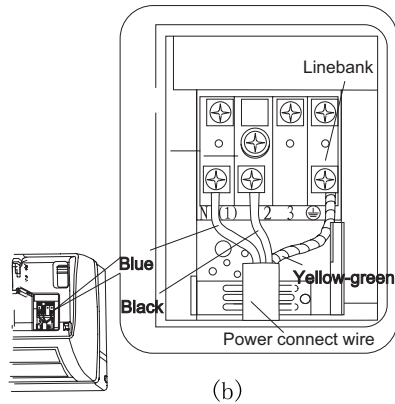

Signal control wire (only for cooling and heating unit)

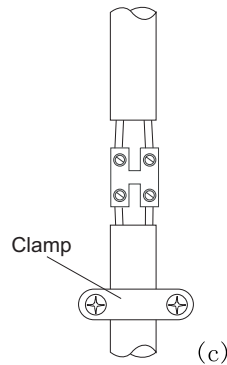

Electric wiring diagram for one to two indoor unit:

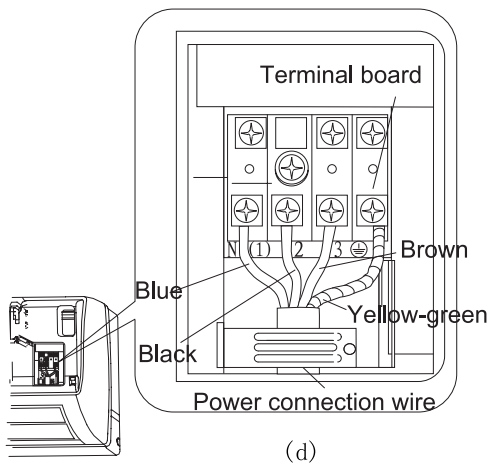

Fig.9-3

6 Install the indoor unit

1. When routing the piping and wiring from the left or right side of the indoor unit (as shown in the following figure 9-4(a), (b)), it is required to cut off the sections from the pipe at the chassis of the system (shown in figure 10--4 (c)).

- (1) Cut down section 1 when only the power cord is led.
 - (2) Cut down sections 1, 2 (or 1, 2, 3) when the connection pipe and wire are led: among them ①, ②, ③ are recommended.
2. Let the piping and cord pass through the piping hole after tired up. (As shown in the following figure 9--5).
3. Hang the claw behind the indoor unit on the pothook on the wall rear panel, move the unit left and right to check if the body is firm (as shown in Fig 9-6).
4. Guarantee that the install height of the indoor unit should above 2.0m from the floor.

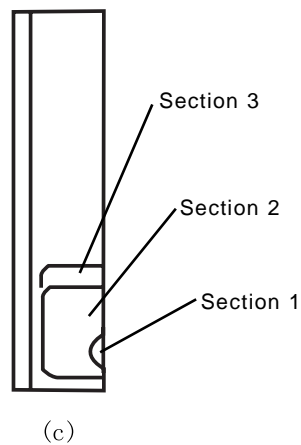
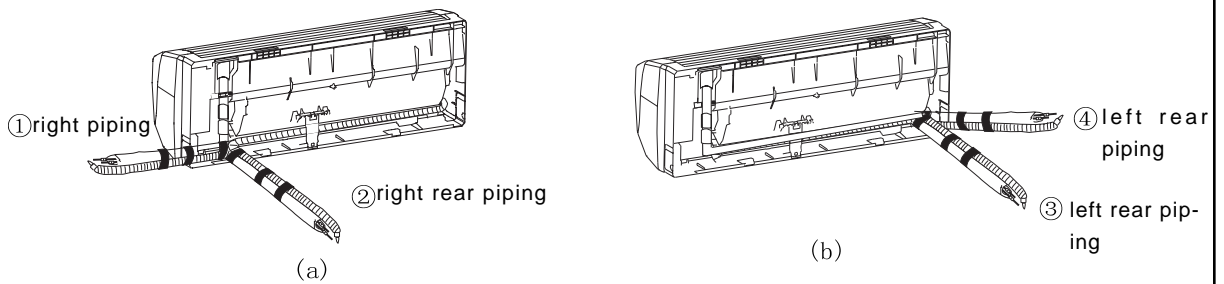

Fig. 9-4

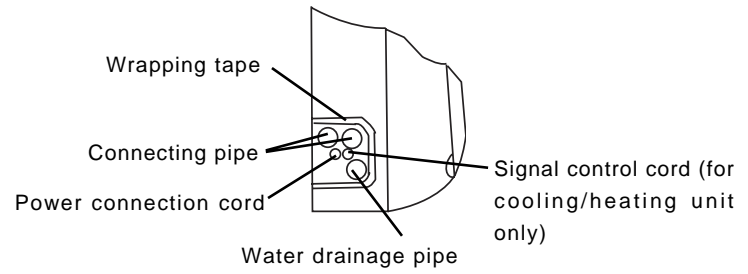

Fig. 9-5

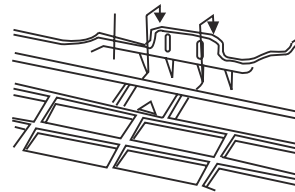

Fig. 9-6

9.3 Install the outdoor unit

1 Install connect pipe

- The flare end of the connecting pipe coincides with the flare end connector of the corresponding valve.
- Tighten nuts on connecting pipe with force then tighten it by spanner. (As shown in Fig.9-7)

Note: Too great of torque may damage nuts.

As shown in following:

Hex nut	Tighten torque (NM)
φ 6	15-20
φ 9.5	31-35
φ 12	50-55
φ 16	60-65

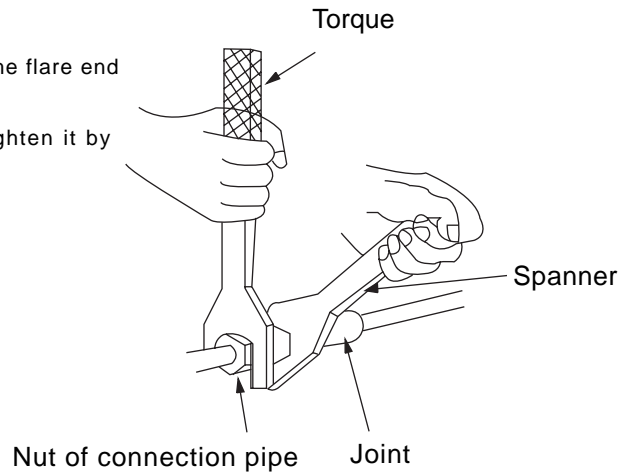

Fig.9-7

2 Wiring connection

- Take off right side big handle of outdoor unit (1 screw)
- Take off clamp, connect and fix the power connect wire to wiring terminal board. The wiring location should be in accordance with that of indoor unit. As shown in Fig.9-8.
- Fix the power lines with line clip. For cooling/heating unit, it is also necessary to fix the signal control one and then, connect the corresponding connector.
- Ensure that wire had been fixed firmly. (as shown in Fig 9-8).
- Install the handle (1 screw fixing)

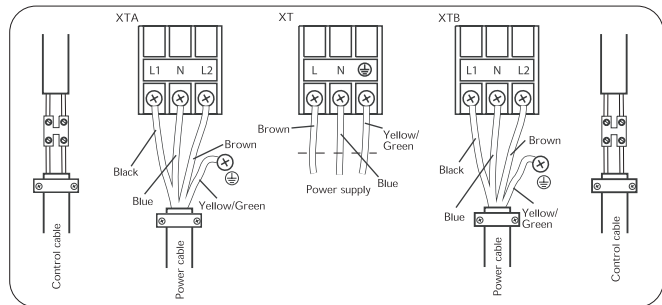
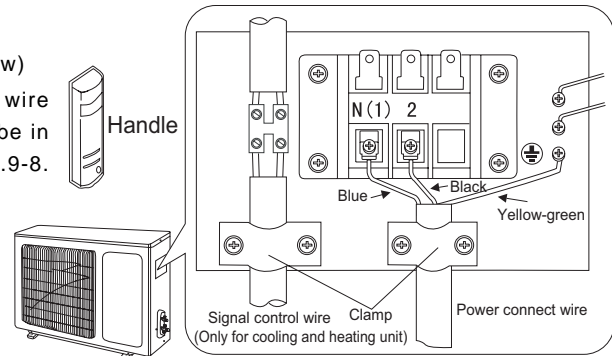
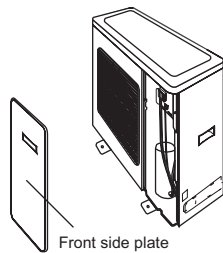

Fig. 10-8

Note:

- Wrong wire connection would cause failure of some electric components.
- After the line fixing, a certain freedom should be given to the conductors leading from the connection points to the fixing location.

3 Evacuation and Leakage Detection

- Remove the screwed nut cap at the stop valve for outdoor unit.
- Fasten the taping nut entirely with hand by aligning the center of the auxiliary pipe.
- Tighten the taping nut with a spanner.
- Remove the valve covers of the liquid valve and gas valve and the nozzle nut for filling freon.
- Screw off the valve core inside the liquid valve with a hexagon spanner. At the same time, top off the air core at the gas valve with a screw driver. In this case there should be gas discharging out.
- After discharging for 15s and when the cooling refrigerant appears, close the gas core and tighten the nozzle nut for filling freon.
- Open completely the valve cores for liquid valve and gas valve (Fig.10-9).
- Screw tightly the valve cover and check for gas leakage at the connection sections between the indoor/outdoor units and the pipes with soap water or leakage tester.
- If condition allows, it is available to evacuate air inside the unit from the gas valve core with a vacuum pump (Fig.9-10)

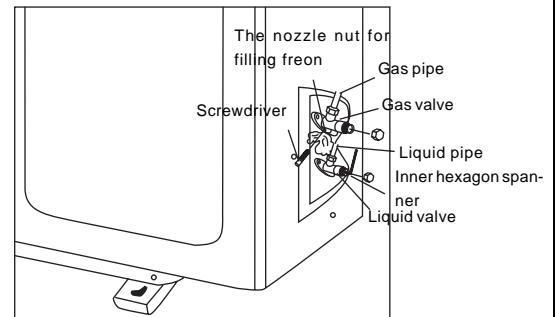

Fig. 9-9

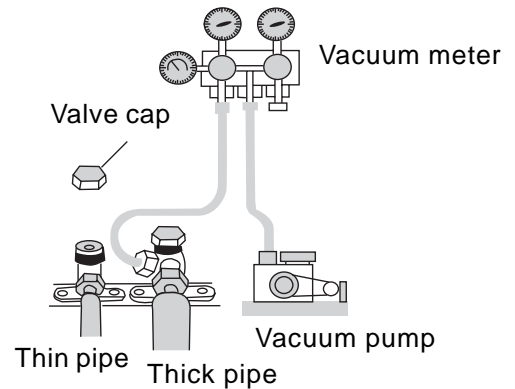

Fig.9-10

4 Drainage of condenser of outdoor unit(no for cooling only unit)

- When heating, condenser water and defrost water produced when defrosting by outdoor unit can be drained to proper place through drainage hose.

Install Method:

- As shown in Fig.11-11, inset and install properly the drainage joint of outdoor unit at $\phi 25$ hole of the chassis. Then, connect the drainage hose to the drainage nuzzle and lead the condensed water and defrosting water to a proper location for drainage.

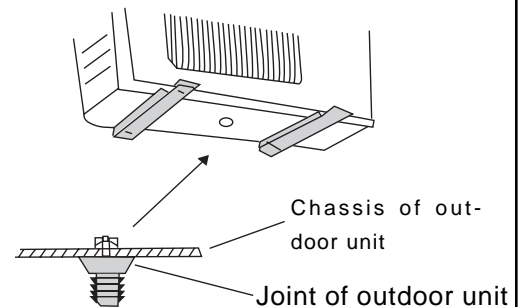

Fig 10-11

9.4 Check Items for Trial Running and after Installation

1 Trial Running

1. Preparation for trial running

- Prior to completing the entire installation, it is not allowed to turn on the power.
- Control circuit should be connected correctly and safely, all wires should be connected firmly.
- The big/small stop valves should be opened.
- All the scattered things, especially metal scraps, thrum and jawsetc. must be removed from the unit.

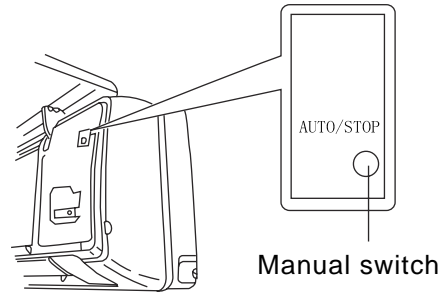

Fig.9 – 11

2. Method of trial running

- Connect with power supply and press ON/OFF button on remote controller.
- Press On/Off of the remote controller and then press MODE to select working mode such as COOL, DRY, HEAT and FAN etc. to see if operations are normal.
- Emergency running: in case of losing the remote controller, it is available to use a ball pen and the like to carry out the operation as follows:
 - (1) At the stop mode, press the button to start the air conditioner, which will enter automatic running mode. The microcomputer inside will select automatically, in accordance with the temperature, the cooling, heating or air supply to obtain a comfortable effect. If it is required to stop running, press the button again.
 - (2) Under run mode, set the button to STOP when unit is running, then the unit will stop working.

2 Check items after installation

Items to be checked	Possible failure
Is the installation firm enough?	Unit may drop, shake or emit noise.
Is leakage test done?	It may cause insufficient cooling (heating) capacity.
Is heat insulation sufficient?	Condensation or drip may occur.
Is drainage smooth?	Condensation or drip may occur.
Is power voltage the same as that listed on nameplate?	Failure or burnt out of parts may occur.
Is installation of circuit and pipeline correct?	Failure or burnt out of parts may occur.
Is unit grounded safely?	Leakage may occur.
Do wire specifications meet the relative regulations?	Failure or burnt out of parts may occur.
Is air inlet or outlet vent of indoor and outdoor unit blocked?	It may cause insufficient cooling (heating) capacity.
Is length of cooling pipe and filling amount of refrigerant recorded?	No available to handle the charging amount of refrigerant.

10 Failure and analysis

